

## **Safe DC SDC-PoE4**

Switch with 4 PoE/PoE+ ports  
integrated Micro-UPS



BACnet IP / HTTPS / SNMP



EN Operating Instructions



<b>1. List of product models</b>	<b>3</b>
<b>2. Safety</b>	<b>3</b>
<b>3. Directives and environment and public health protection</b>	<b>4</b>
<b>4. Definition of the symbols</b>	<b>4</b>
<b>5. General Information</b>	<b>5</b>
5.1 The company	5
5.2 Purpose of the document	5
5.3 Related documentation	5
5.4 Intended audience	5
5.5 Indicator labels	5
<b>6. The product</b>	<b>6</b>
6.1 Description	6
6.2 Operating principle	6
6.3 Schematic diagram	7
6.4 Product view	7
6.5 Scope of delivery	8
<b>7. Energy storage</b>	<b>9</b>
7.1 Available storage option	9
7.2 Technology	9
7.3 Autonomy curves	10
7.4 Autonomy duration	10
7.5 Self-discharge	Erreur ! Signet non défini.
<b>8. Installation</b>	<b>11</b>
8.1 Positioning / Installation on support	11
8.2 Connection	12
8.2.1 Connection specifications	12
8.2.2 Wiring	12
<b>9. Commissioning</b>	<b>14</b>
9.1 Communication protocols	14
9.2 Installing the root certificate	14
9.3 Assigning an IP address	15
9.4 Login page – Logging onto the product	15
9.5 Configuration page – General settings' configuration	16
9.6 Network page – IP connection and Ethernet information configuration	17
9.7 Power Supply page – Power supply configuration	20
9.8 System State page – Access to system information	21
9.9 Log page – Access to event log	22
9.10 Factory configuration reset	25

9.11	Product switch-off	25
<b>10.</b>	<b>Operation</b>	<b>26</b>
10.1	Local report on product	26
10.2	Remote report – Communication	27
10.2.1	Accessible data	28
10.2.2	HTTPS Protocol	29
10.2.3	SNMP Protocol	30
10.2.4	BACnet IP Protocol	32
<b>11.</b>	<b>Maintenance and troubleshooting</b>	<b>43</b>
<b>12.</b>	<b>Technical data</b>	<b>45</b>
12.1	Electrical characteristics	45
12.1.1	Electrical characteristics of the power supply	45
12.1.2	Electrical output characteristics	47
12.2	Functional characteristics	48
12.3	Mechanical characteristics	48
12.4	Environmental specifications	48
12.5	Standards	49
12.5.1	Safety standards	49
12.5.2	EMC standards	49
12.5.3	IEEE standards	49
<b>13.</b>	<b>Warranty and Product Returns</b>	<b>50</b>
13.1	Warranty	50
13.2	Product Returns	50
13.2.1	Product under warranty	50
13.2.2	Product not under warranty	51

## 1. List of product models

---

These operating instructions apply to all products in the table below.

Models	Code
SDC-PoE 3D BOX2 P4	83930924
SDC-PoE 3E BOX 2 P4	83931924

Table 1.1: List of product models

## 2. Safety

---

These operating instructions contain all the instructions to follow in order to install, commission and operate the switch with integrated emergency power supply **SDC-PoE4**. It is recommended to follow them very carefully to ensure an optimum functioning of the product.

It is vital to read the Safety Precautions before installing or starting to operate this product.

### Safety Precautions:

**SDC-PoE4** is an equipment designed to be connected to the public 110 V / 240 V mains network. It must not be installed outdoors. It ensures continuity of service for equipment in case of power failure. The lithium backup function is integrated into the product.

- An easily accessible two-pole circuit-breaker must be provided upstream.
- To avoid any risk of electric shock, all **INTERVENTIONS** must be carried out with the equipment **SWITCHED OFF** (upstream two-pole circuit-breaker open).
- Interventions with the equipment switched on are authorized only when it is impossible to switch the equipment off. The operation must only be performed by qualified personnel.
- During installation, connect the ground wire first and disconnect it last when dismantling.
- The equipment is only designed to be placed on a horizontal surface and to be installed on a concrete surface or any other non-combustible surface.
- The product can be installed horizontally or vertically.
- EN 62368-1 conformity (This equipment is not suitable for use in locations where children are likely to be present).
- Sufficient convection must be guaranteed (minimum side clearance space 30 mm).
- The wires must be dimensioned and protected according to the maximum input/output current ( $\geq 0,15 \text{ mm}^2/\text{A}$ ).
- Observe the thermal and mechanical limits.
- For prolonged storage or disconnection, cut the mains and press the stop button back-up function (see on Figure 6.2 in chapter 6.4: Product view ).
- The backup is maintenance-free. Do not open it.

### 3. Directives and environment and public health protection

The SLAT company is, through their products, committed to protecting the environment and the public health and complies with the corresponding directives.

SLAT develops and manufactures all its products in accordance with the environmental directives RoHS (Restriction of Hazardous Substances) and WEEE (Waste of Electrical and Electronic Equipment).



At its end of life, the product has to be recycled. For end-of-life recycling, a plug-in connector enables qualified professionals independent from SLAT to easily remove the backup.



The SLAT products are compliant with the CE directives.



### 4. Definition of the symbols



Conformity of the product with the requirements of the European directives.



**WEEE (WASTE ELECTRICAL AND ELECTRONIC EQUIPMENT)**

Disposal of the product in an appropriate collection and recycling structure.  
This product should not be disposed of with household waste.



**RoHS (RESTRICTION OF HAZARDOUS SUBSTANCES)**

Compliance with the European Directive restricting the use of certain hazardous substances in electrical and electronic equipment.



Protective earth terminal.



Caution, risk of electric shock.

## 5. General Information

---

### 5.1 The company

To meet its customers' requirements more effectively:

- SLAT has been designing and manufacturing all its products in accordance with the ISO 14001 standard v15.
- SLAT recycles its products at the end of their life cycle, by means of its recycling program.

### 5.2 Purpose of the document

The operating instructions provide the information necessary for the positioning, the connection, the configuration and the operation of the **SDC-PoE4** equipment.

These instructions are also available in PDF format in MYSLAT at [www.slat.com](http://www.slat.com).

### 5.3 Related documentation

The following documents are associated with these operating instructions:

- Installation manual
- Commercial brochure

This documentation is available at [www.slat.com](http://www.slat.com).

### 5.4 Intended audience

The operations described in this document should be performed only by authorized trained staff.

### 5.5 Indicator labels

This document comprises three types of important notices.

The type of notice informs you of the potential consequences in the case of non-compliance with the instructions.

These consequences are not exhaustive and are sorted in order of ascending risk:



#### **IMPORTANT REMARK!**

**Contains additional information. Non-compliance will not cause damage to equipment or personal injuries.**

---



#### **CAUTION!**

**Equipment and goods can be seriously damaged or people seriously injured if the precautions for use are not followed.**

---



#### **DANGER!**

**Non-compliance may result in serious injury or death.**

---

## 6. The product

### 6.1 Description

#### 4 port switch with lead and cadmium-free "Smart Backup Inside" with very long service life.

The **SDC-PoE4** is a backed up PoE/PoE+ switch (endspan) with integrated Micro **UPS (Uninterruptible Power Supply)** of the Safe DC range dedicated to the PoE applications (e.g. video or data transmission). It ensures the continuity of service of the PoE equipment they supply and maintains communication with the supervisor in the event of a power failure. SDC-PoE4 is installed as close as possible to the applications and provides all the advantages for optimizing wiring and simplifying maintenance. It also allows to provide selectivity of electrical protections of the equipment.



#### Built-in functions

- Powers the PoE/PoE+ equipment according to IEEE 802.3af and IEEE 802.3at
- Secures up to 4 PoE / PoE+ equipments
- Total PoE budget 60 W
- Integrated 15 min to 5h back up
- Integrated LiFePO<sub>4</sub> backup, very long service life
- Configurable reboot function for each port
- Open communication protocols: SNMP, HTTPS and BACnet IP

#### Benefits of the SDC-PoE4

- Protects PoE equipment against any electrical disturbance, internal or external
- Ultra-compact & Plug and Play
- Performs self-diagnostic and that of its environment
- Saves wiring
- 4 protected Ethernet ports 100 Mbps / 1 protected Ethernet port 1000 Mbps

### 6.2 Operating principle

When connected to the mains, the emergency power supply of the switch SDC-PoE4 stores energy and continuously powers the connected devices.

When the mains fail, the built-in emergency supply continues to provide power to the connected devices without interruption.

In the event of a complete discharge, the recharging time to 100% of the backup will in all cases be less than 20 hours of mains presence.

### 6.3 Schematic diagram

The visual below shows the product diagram:

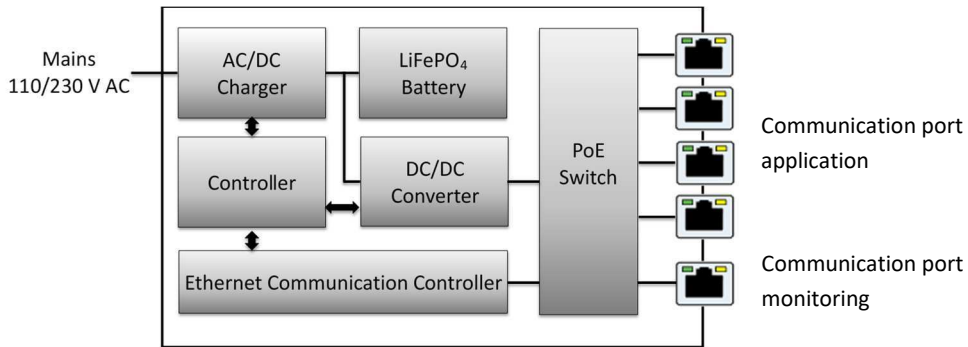

Figure 6.1: Schematic diagram

### 6.4 Product view

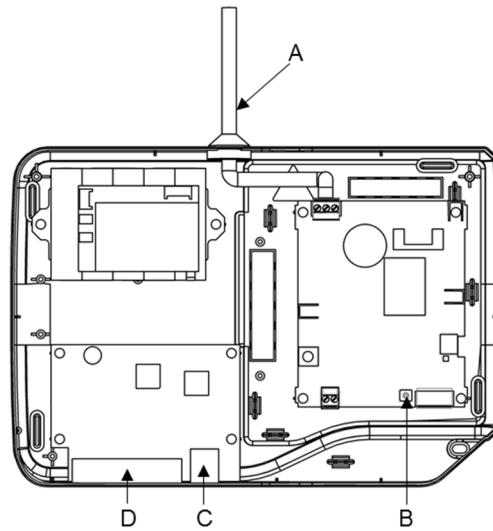

Figure 6.2: Interior view

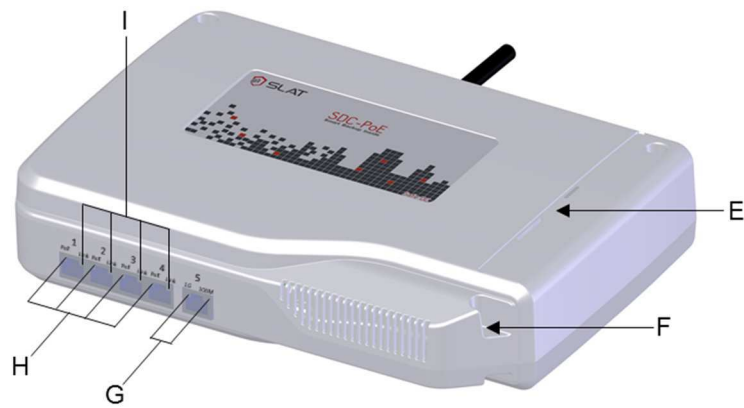

Figure 6.3: Exterior view

	Name	Use
A	Mains input	Mains input via prewired cable.
B	Disconnect backup push button	The push button is used to switch off the product once the mains power is cut or to return to the factory configuration when the mains is present.
C	Ethernet-Port	Uplink Ethernet Port: 10/100/1000 Mbps The communication uses an Ethernet connection and the SNMP, HTTPS or BACnet IP protocol to retrieve detailed product information (see chapter 10.2).
D	Ethernet-Port (PoE/PoE+)	Downlink Ethernet Port: 10/100 Mbps The communication uses an Ethernet connection and the SNMP, HTTPS or BACnet IP protocol to retrieve detailed product information (see chapter 10.2). Using this port, the Ethernet connection supplies over PoE/PoE+ the connected device.
E	Status light (Status LED)	The light indicates the product status (see chapter 10.1).
F	Security seal hole	Hole for installing a security seal on the box
G	Communication speed light (Uplink LED)	The lights indicate the communication speed with the supervisor (see chapter 10.1).
H	PoE status light (PoE LED)	The lights indicate the PoE status (see chapter 10.1).
I	Connection status light (Link LED)	The lights indicate the status of the connection ("link") (see chapter 10.1).

Table 6.1: Elements on the product faces

## 6.5 Scope of delivery

The product is delivered with its installation manual.

## 7. Energy storage

### 7.1 Available storage option

SLAT products are combined with batteries or backup systems. They are used as emergency supplies in the event the mains voltage disappears. The available autonomy then depends on the capacity of the built-in backup.

In the **SDC-PoE4** the backup system is already built-in (Smart Backup Inside). According to the need, the product is fitted with different backups. For the BOX2 version of the SDC-PoE4, two backup packs are available. The Table 7.1 presents their minimum guaranteed capacity.

Backup D	Backup E
20 Wh	40 Wh

Table 7.1: Backup versions

### 7.2 Technology

The technology behind the SDC-PoE4 backup is Lithium-Iron-Phosphate (LiFePO<sub>4</sub>). LiFePO<sub>4</sub> offers the best safety characteristics of any Lithium storage system (see Figure 7.1). This includes better resistance to impacts and to extreme temperatures.

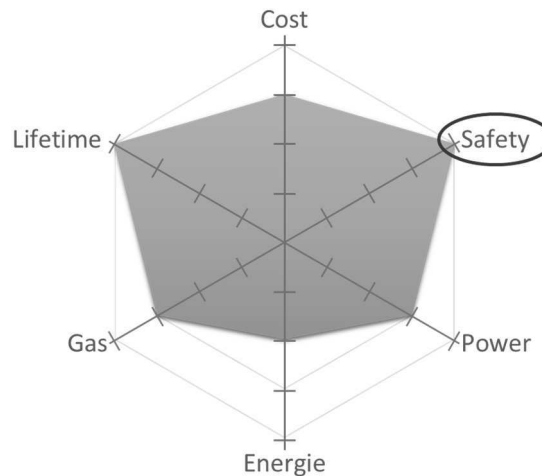

Figure 7.1: LiFePO<sub>4</sub> characteristics

All SDC-PoE4 backups have the following characteristics:

- Lithium-Iron-Phosphate technology (LiFePO<sub>4</sub>)
- No risk of thermal runaway
- Storage: 9 months without recharging
- 10 year service life @ 25°C
- Lead-free, cadmium-free, 100% recyclable

### 7.3 Autonomy curves

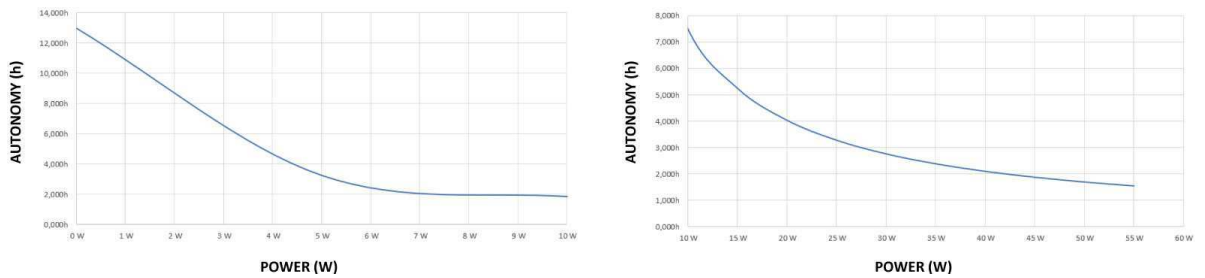

Figure 7.2: Autonomy curves Backup D at 20°C

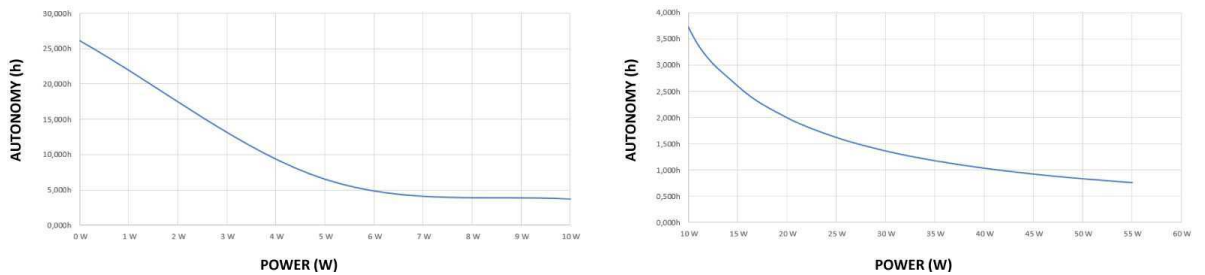

Figure 7.3: Autonomy curves Backup E at 20°C

### 7.4 Autonomy duration

	Backup D	Backup E
<b>Operating power</b>	<b>Autonomy expressed in hours and minutes</b>	
0 W	12h59	26h09
5 W	3h15	6h32
10 W	1h51	3h43
15 W	1h17	2h36
20 W	0h59	2h00
25 W	0h48	1h37
30 W	0h40	1h21
35 W	0h35	1h10
40 W	0h30	1h01
45 W	0h27	0h55
50 W	0h24	0h49
55 W	0h22	0h45

Table 7.2: Autonomy vs Power vs used Backup at 20°C

A part of 20 Wh of the backup D or 40 Wh of the backup E is used for the operation of the SDC POE4 BOX 2 in autonomy mode.

To obtain the autonomy times at 55°C please apply a multiplication coefficient of 1,052.

To obtain the autonomy times at -10°C please apply a multiplication coefficient of 0,614.

## 8. Installation

The product must be installed according to the 62368-1 standard.

### 8.1 Positioning / Installation on support

The BOX2 is designed to be **placed horizontally or to be mounted vertically** in an enclosure with restricted access. It can be fitted inside a non-ventilated electrical equipment cabinet. Product cooling by natural convection requires a side clearance of at least 30 mm

#### Instructions for a horizontal mounting

The BOX2 can be placed on a horizontal support (cabinet, Voice/Data/Image housing, etc.). When the box is not fixed to a surface, it's not necessary to open it to do the installation.

#### Instructions for a vertical mounting

The BOX2 housing is also designed to be fixed to a wall. The product is installed with the cover off. The cover must be removed by first unscrewing the two cover retaining screws (see Figure 6.3) with a screwdriver (captive screws).

Secure then the box to the wall using 4 screws, as shown in Figure 8.1.

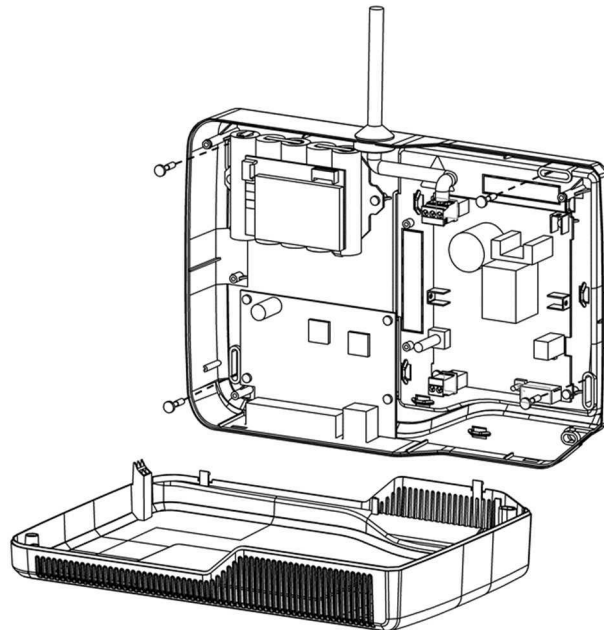

Figure 8.1: Screw mounting

Figure 8.2 shows how the box must be positioned on the wall once assembled.

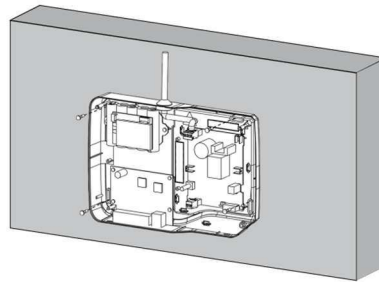

Figure 8.2: Wall mounting

A protective device is available to ensure product security. The unit can be sealed with a security seal to detect unauthorised opening of the cover (see Figure 6.3).

## 8.2 Connection

### 8.2.1 Connection specifications

Mains		Prewired power cable L/N/PE
Ethernet Ports 1 to 4 (PoE)	Connection 10/100 Mbps	Ethernet cable Cat 5 or more / shielded or unshielded / straight or twisted cables
Ethernet Port 5	Connection 100 Mbps	Ethernet cable Cat 5 or more / shielded or unshielded / straight or twisted cables
	Connection 1000 Mbps	Ethernet cable Cat 5e or more / shielded or unshielded / straight or twisted cables

Table 8.1: Connection specifications



#### **DANGER!**

The wire sectional area must be chosen according to the operating current.

### 8.2.2 Wiring

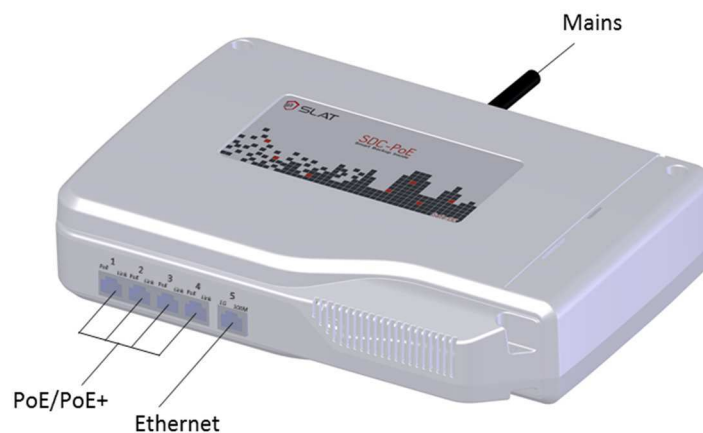

Figure 8.3: Wiring

After installing the product on its support, the wiring must be carried out. In this way, the emergency power supply (the product) is connected to the application, the supervisor and the mains.

To connect the wires, the cover doesn't need to be opened because the Ethernet ports and the mains input cable are accessible from the outside.

The Ethernet ports are auto MDI-X, such that either straight-through or twisted cables can be used.

## Connection



### **DANGER!**

**To connect the wires, the application must be switched off. The upstream circuit-breaker of the application must be open!**

The wires are connected according to the following steps:

#### 1. Connect the product to the mains

The mains input cables have to be connected to the prewired cable emerging from the top of the box (see Figure 8.3). Connect the following three wires respecting their color:

- Green-yellow wire                      Ground wire
- Blue wire                                    Neutral wire
- Brown wire                                Line wire

After connecting the ground wire, the neutral and line wires can be connected.

⇒ Once the connection of the mains has been made, the upstream circuit-breaker can be closed. To complete the installation, the Status LED on the cover must be verified to be green.



### **DANGER!**

**The ground wire must always be connected before connecting the power supply to the mains!**

#### 2. Connect the product to the applications

The product is connected to the PoE/PoE+ applications by the Ethernet ports 1 to 4.

This connection allows to:

- Supply the application, when it is PoE compatible (the output voltage is set in accordance to the PoE standards).
- Assure the communication with the application.

### **Communication:**

The four Ethernet ports with PoE/PoE+ function (Ports 1 to 4) allow the communication with an application like a camera or an external controller. The communication speed is 10 / 100 Mbps. Each port is numbered (see symbols in Figure 8.3 or on the product) and can be used independently.

The Port 5 allows the communication with the supervisor. The communication speed is 10 / 100 / 1000 Mbps.

## 9. Commissioning

Before starting to commission the switch, check that the Status LED on the cover is green. This means the product is powered properly and ready to function.

The communication parameters can be configured via the HTTPS website. It also makes it possible to configure the energy saving mode (ECO) and the stealth mode.

In order to communicate with the product, it must be configured according to the following chapters. The computer's network configuration, to which the product will be connected to, has to be compatible with the product's network parameters.

### 9.1 Communication protocols

The product supports the following communication protocols.

#### Application layer protocols

- HTTPS
- BACnet IP
- SNMP v1, v2c or v3
- DHCP

#### Network layer protocols

- IPv4
- ICMP

### 9.2 Installing the root certificate

To use the products in HTTPS and to communicate safely with them the SLAT root certificate must be installed on the user's computer. This certificate is valid for all SLAT products and can be downloaded from the Library Account on the [www.slat.com](http://www.slat.com) website.

The **root certificate** is named **SLAT\_ca\_cert.crt**

The certificate must be installed in the certificate store: "Trusted Root Certification Authorities"

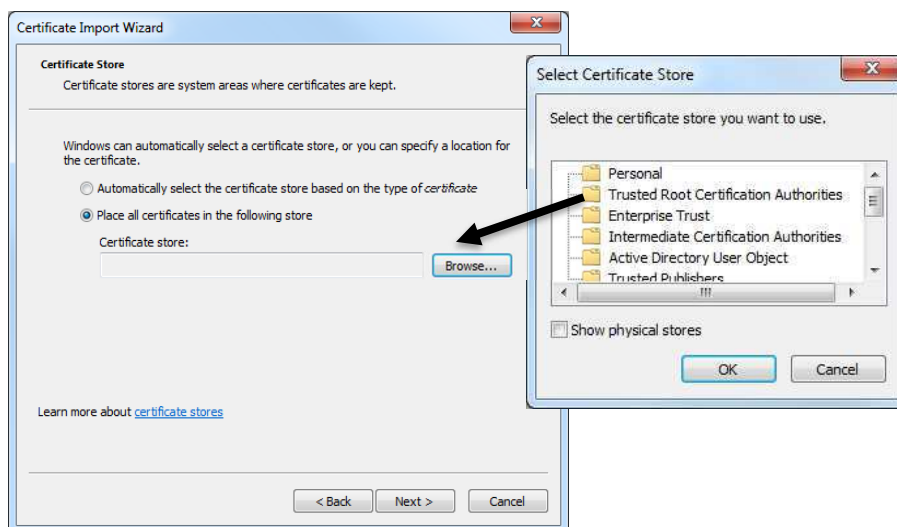

Figure 9.1: Selecting the certificate store

### 9.3 Assigning an IP address

The DHCP (dynamic IP address allocation) automatically assigns an IP address to a product in order to communicate with it. This feature is enabled by default in the factory configuration.

Two different operating modes exist according to the availability or lack of a DHCP server on the network:

A. DHCP server available

If a DHCP server is available, it automatically allocates an IP address to the product. If several products are connected to the network, it assigns a different IP address to each one.

To determine the new address, browse the network

B. DHCP server not available

If no DHCP server is available on the network, the product uses the IP settings below. When the switch is first connected to the network, it remains in DHCP for 1 minute before switching to the predefined IP address:

- IP address            192.168.1.1
- Network mask        255.255.255.0
- No gateway

In this case, if several products need to be connected to a single network, as they possess the same IP parameters, they must be isolated and the IP address of each product must be modified using their HTTPS web interface before being connected to the network in order to avoid any address conflicts.

The same procedure applies if the same IP address exists several times on a given network. See chapter 9.6. for instructions on changing the IP address.

### 9.4 Login page – Logging onto the product

Using the allocated or predefined IP address, it is possible to log onto the product using a web browser (over HTTPS). The language used is that of the web browser.

---

**IMPORTANT REMARK!**



The default login and password are:

**Login:                    admin**

***There is no password. Click directly on "OK".***

**For the security of your installation, it is imperative to set a password!**

---

Once connection with the product has been established, the "SYSTEM STATE" page is displayed (see chapter 9.8). The default language of the administrator's embedded web site is English.



The screenshot shows the login interface for the SLAT SDC-PoE device. At the top left is the SLAT logo. To the right, it says "SDC-PoE" and "Firmware V2.3A Support" with a red "Support" link. Below this, there are four input fields: "Login:" with a text box, "Password:" with a text box, "Retain:" with a checkbox, and "Submit:" with a button labeled "OK".

Figure 9.2: Login page

## 9.5 Configuration page – General settings' configuration

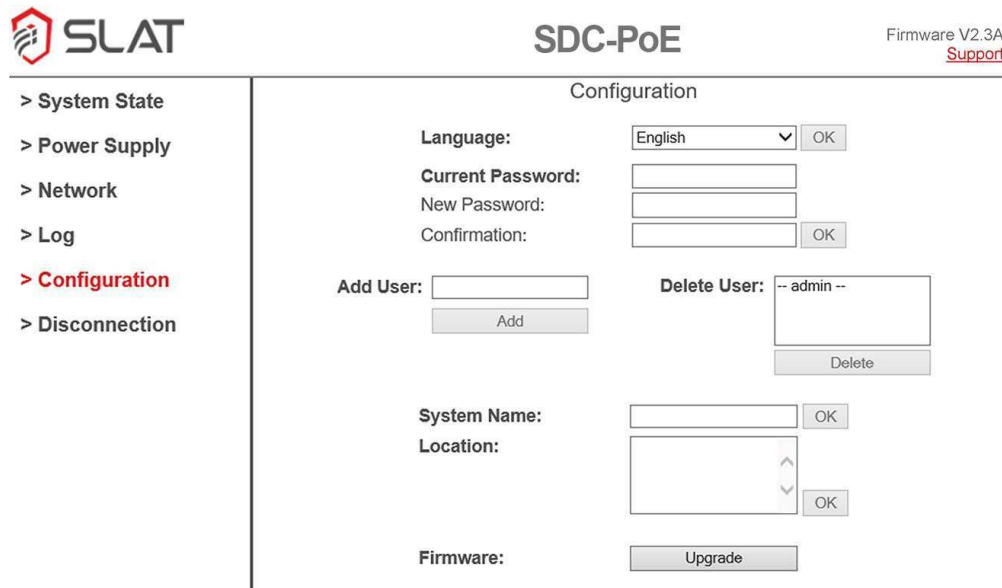

Figure 9.3: Configuration page

To configure the product, click on the "CONFIGURATION" tab in the left-hand menu. This page allows to perform the following configuration operations (see also Figure 9.3). Confirm the operations by clicking on the button next to them ("OK", "Add", "Delete", "Update").

1. **Change language**
2. **Change password**
3. **Add user**  
Up to 8 users (including the administrator) can be created. By default, the user account is created in the same language as that of the administrator. It can be changed as required.  
A new user does not need to enter a password. Upon initial logon, he/she may define a new password, if desired, via the "CONFIGURATION" page.
4. **Delete user**
5. **Enter the system name**  
The system name with up to 16 characters can be entered. Over HTTPS, the name always possesses the prefix "SDC-". This information is also available over SNMP and BACnet IP, but without the prefix.
6. **Enter the product location**  
The location here defined is shown on the "SYSTEM STATUS" page (see chapter 9.8). This information is also available over SNMP and BACnet IP.
7. **Updating Firmware (communication)**  
The communication firmware can be updated to install new functions. The current version is displayed in the top right-hand corner of the page.

Operations 1 and 2 can be performed from all accounts (administrator and users). Operations 3 to 7 however, can only be performed by the administrator.

## 9.6 Network page – IP connection and Ethernet information configuration

SLAT SDC-POE Firmware V2.3A Support

Network

Port	Link	IP Address	PoE	DAM	
Port1 -	-	0.0.0.0	Standby	Off	OK
Port2 -	-	0.0.0.0	Standby	Off	OK
Port3 -	-	0.0.0.0	Standby	Off	OK
Port4 -	-	0.0.0.0	Standby	Off	OK
Port5 -	1000Mb/s	0.0.0.0	-	-	OK

Update

Green Ethernet (EEE):  OK

DHCP:

System IP Address: 192.168.1.1

Network Mask: 255.255.255.0

Gateway IP Address: 0.0.0.0 OK

NTP Server IP Address #1: 0.0.0.0

NTP Server IP Address #2: 0.0.0.0

System Timezone Offset (minutes): 0 OK

BACnet: Read-Only OK

SNMP: V3 - Read-Only

USM User:

Auth Algorithm: MD5

Auth Password:

Privacy Algorithm: DES-CBC

Privacy Password: OK

SNMP Server IP Address #1: 0.0.0.0 OK

SNMP Server IP Address #2: 0.0.0.0 OK

[SNMP MIB Download](#)

Figure 9.4: Network page

To configure the IP connection, click on the "NETWORK" tab in the left-hand menu. This page displays all connection-related information (e.g.: connected ports, IP address).

The administrator can access and edit all information. Users can only view the information concerning each port (1) and the product's IP parameters (3).

### 1. Port configuration

The table shows the configuration and status of each of the five ports on the SDC-PoE4.

To save changes made to a port, click on "OK" to the right of the same row.

- Port**

This column contains the port identifier. It can be customized as required by entering a name of up to 11 characters in the right-hand box.

If an IP address has been entered in the "IP Address" column, then the text "Port X" is a hypertext link to this same IP address.
- Link**

This column indicates whether an Ethernet link has been established, displaying the connection speed:

  - Port 1 to 4: 10 or 100 Mbps
  - Port 5: 10, 100 or 1000 Mbps
- IP Address**

This field is used to enter an IP address. If this IP address is different from "0.0.0.0", it changes the "Port X" identifier to a hypertext link to this same IP address.

- **PoE**  
 This field indicates the PoE status and the potential consumption. It also allows to pilot this. Note that only Ports 1 to 4 are PoE and that Port 5 is not.  
 Once the PoE is active, without a connected application the indicated status is “Standby”. By connecting an application to one port, a PoE budget for this port is negotiated (“Starting”). The PoE class defines a power range (maximum 12.95 W for PoE and 25.5 W for PoE+). Once the negotiation has finished, the power consumption is indicated in this field.  
 The PoE for each port can manually be stopped (“Off”) or activated (“On”).  
 It is also possible to manually do a reset of the PoE of each port (“Restart”): The PoE power supply stops for 8 seconds and restarts automatically. It stays in standby while waiting for a new negotiation (like when a new application is connected to the product).
  
- **DAM (Device Activity Monitoring)\***  
 This field allows to control the DAM function, which authorizes the surveillance of the applications, connected to the ports 1 to 4 (PoE). The administrator can activate (“On”) or disable (“Off”) this function. It is disabled by default.  
 Once the function is active, it remains on standby waiting for the connected application to start and to answer to the regularly sent inquiries. As soon as the application has started, it answers to the inquiries and thus activates the DAM supervision and protection of the application. In case the application does no longer answer, the DAM launches an automatic restart for the corresponding PoE port.  
 For the DAM function being operable, the connected application’s IP address has to be entered in the field “IP Address”.

\*This function is only available for products with the identification “DAM”.

#### Updating the information

The data are automatically refreshed every 10 seconds, except when an edit operation is in progress. By clicking on "Update", the data can be manually refreshed.

## 2. Green Ethernet configuration (EEE – Energy-Efficient-Ethernet)

The Green Ethernet function allows to reduce automatically the power consumption of an Ethernet link depending to its usage. To save the configuration of the Green Ethernet, checked the box and click on « OK » to the right on the same line.

Some incompatibilities can cause instability of the Ethernet link. In this case, it is recommended to disable the Green Ethernet.

## 3. Uplink mode configuration

The Uplink Mode can be activated to control the data flow (box to the right of Uplink Mode checked). The port 5 will be used as an Uplink port. All the multicast streams gets out through the port 5.

## 4. Product IP parameter configuration

The product's IP parameters consist of its IP address, network mask and gateway IP address. These parameters can be automatically assigned by DHCP, or entered manually. DHCP is enabled by default. It's only possible to function in DHCP if a DHCP server is available on the network.

The following paragraph explains how to change the product's IP parameters:

- Automatic IP parameter assignment  
 For an automatic assignment, the DHCP must be enabled (box to the right of DHCP checked). Click on "OK" next to "Gateway IP Address". The DHCP server allocates a new IP address to the product. It is necessary to explore the network to know the new address.
  
- Manually entering IP parameters

To enter the IP parameters manually, DHCP must be disabled (box to the right of DHCP unchecked). Enter the new parameters into the three fields below (product IP address, network mask and gateway IP address). If the gateway feature is to be disabled, enter the gateway IP address of "0.0.0.0". Click on "OK" next to "Gateway IP Address" to save the configuration. The user is automatically re-routed to the new address (login page).

## 5. BACnet IP protocol configuration

The BACnet IP protocol can operate in one of the following modes:

- Read/Write  
The data can be viewed and modified via the BACnet IP protocol. Actions can be implemented.
- Read Only  
The data can only be viewed via the BACnet IP protocol.
- Disabled  
The BACnet IP protocol is disabled.

Click on "OK" next to "BACnet" to save the configuration.

## 6. SNMP protocol configuration

The product supports SNMP versions V1, V2c and V3. The SNMP protocol can operate in one of the following modes:

- Read/Write  
The data can be viewed and modified via the SNMP protocol. Actions can be implemented.
- Read Only  
The data can only be viewed via the SNMP protocol.
- Disabled  
The SNMP protocol is disabled.

Version SNMP V1 and V2c: Click on "OK" next to "SNMP" to save the configuration.

Version SNMP V3:

- USM User  
Create a login.
- Auth Algorithm  
Choose the algorithm to hash the password corresponding to the login.
- Auth Password  
Enter a password of between 8 and 16 characters.
- Privacy Algorithm  
Choose the encryption algorithm.
- Privacy Password  
Enter an encryption code of between 8 and 16 characters.

Click on "OK" next to "Privacy Password " to save the configuration.

If the user wishes to receive SNMP traps, he/she must configure the IP address of the SNMP servers receiving them. To save the changes, click on "OK" to the right of the same row.

If the function is to be disabled, enter the IP address of "0.0.0.0".

Two SNMP servers can be entered.

## 7. Loading the MIB

The SNMP MIB (Management Information Base) can be downloaded here. In case the download doesn't start, verify that it isn't blocked by the internet browser.

## 9.7 Power Supply page – Power supply configuration

The "POWER SUPPLY" page contains information relating to the battery and its use. Only the administrator is authorized to edit this information. Users can only view them.

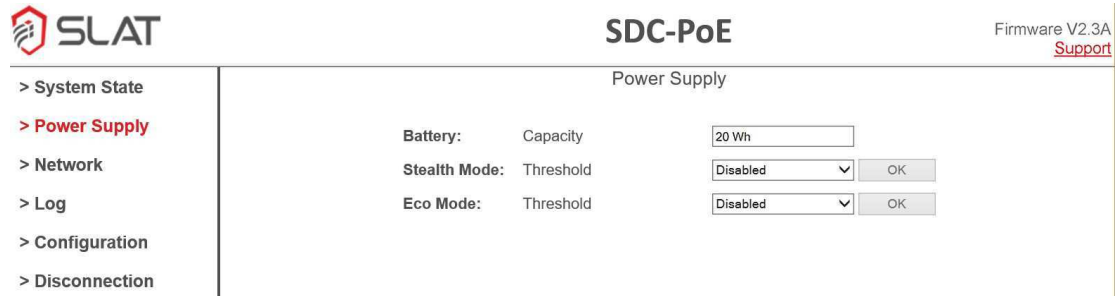

SLAT		SDC-PoE		Firmware V2.3A <a href="#">Support</a>
> System State	Power Supply			
> <b>Power Supply</b>	Battery:	Capacity	<input type="text" value="20 Wh"/>	
> Network	Stealth Mode:	Threshold	<input type="text" value="Disabled"/>	<input type="button" value="OK"/>
> Log	Eco Mode:	Threshold	<input type="text" value="Disabled"/>	<input type="button" value="OK"/>
> Configuration				
> Disconnection				

Figure 9.5: Power Supply page

### Battery

The capacity displayed is the battery's minimum capacity. The value is given for information purposes and cannot be changed. It differs from the capacity's typical value given on the product label

### Stealth Mode

The Stealth Mode allows supervision to stop the product consumption to relieve network load. The product automatically pass in normal operation once the remaining autonomy has reached the guaranteed autonomy percentage selected by the administrator during configuration.

To enable the Stealth Mode, the threshold (percentage of the guaranteed autonomy when Stealth Mode is used) must be defined: 25% / 50% / 75% / Disabled. Click on "OK" to the right to save the new threshold.

### Eco Mode

When enabled, the Eco Mode improves power efficiency at low charge (<20% of  $I_{max}$ ), while guaranteeing a defined percentage of autonomy. In the factory settings, the Eco Mode is disabled by default.

To enable the Eco Mode, the threshold (percentage of the autonomy that must remain available to the user) must be defined: 50% / 60% / 70% / 80% / Disabled. Click on "OK" to the right to save the new threshold.

## 9.8 System State page – Access to system information

Once connection with the product has been established, the "SYSTEM STATUS" page is displayed. Figure 9.6 and the following paragraph describe the information displayed on this page.

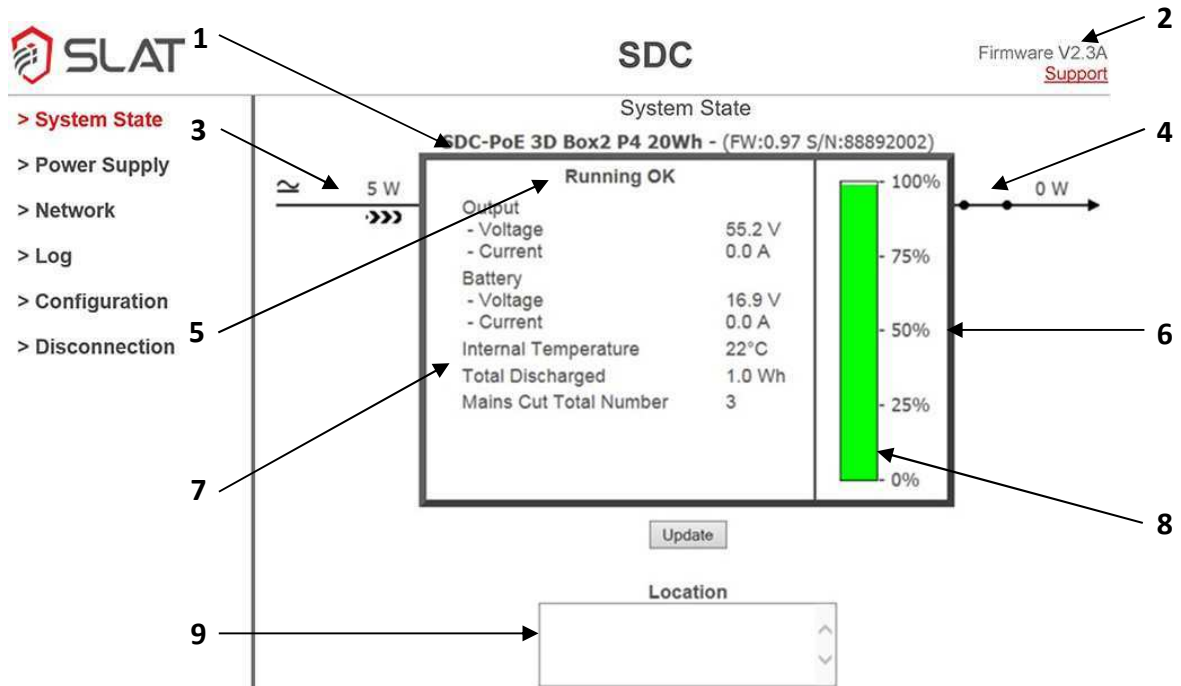

Figure 9.6: System State page

The "System State" page displays the operating status and all the physical values measured by the product. It is refreshed every 10 seconds. To manually refresh the data, click on "Update".

### 1. Product description

- Reference and version
- Actual capacity in Watt-hours
- Power supply firmware version and serial number

### 2. Communication firmware version and support

You can use the "Support" link to send an email to SLAT's after-sales service.

### 3. Mains input

Mains power is indicated by the pictogram on the left in Figure 9.6. If no mains power is present, a red cross is displayed over the pictogram. The value displayed indicates mains consumption in Watts.

### 4. Output

When the breaker is closed, the PoE applications are powered by the product. If the breaker is open, the backup is reaching the end of its autonomy: disconnection and interruption of the power supply are imminent. The value indicates the total PoE power supplied to the devices in Watts.

### 5. Product operating status

The text indicates whether product operation is ok, or whether there is a product fault

### 6. Operating mode

The product operating mode is indicated by the frame color:

- Operating on mains                      gray frame
- Operating on backup                    orange frame
- Eco or Stealth Mode                    green frame

**7. Operation-related data**

- Output current and voltage
- Battery voltage and current  
If the displayed battery current is negative, the battery is discharging.
- Safe DC's internal temperature
- Total Watt-hours drained from the Safe DC since product factory inspection and commissioning
- Total number of power cuts since product factory inspection and commissioning

**8. Charge gauge**

The gauge shows the backup pack's charge status. The backup pack must be fully charged once before the gauge will display an accurate reading.

**9. Location**

The location defines the place where the product is installed. This information can be changed in the "CONFIGURATION" page (see chapter 9.5).

**9.9 Log page – Access to event log**

To access the event log, click on the «Log» heading in the menu on the left. On this page the event history is displayed. It can be filtered in four categories: power, network, configuration and miscellaneous. The history can contain up to 100 events, the oldest being deleted automatically. The filtered event list can be downloaded as text.

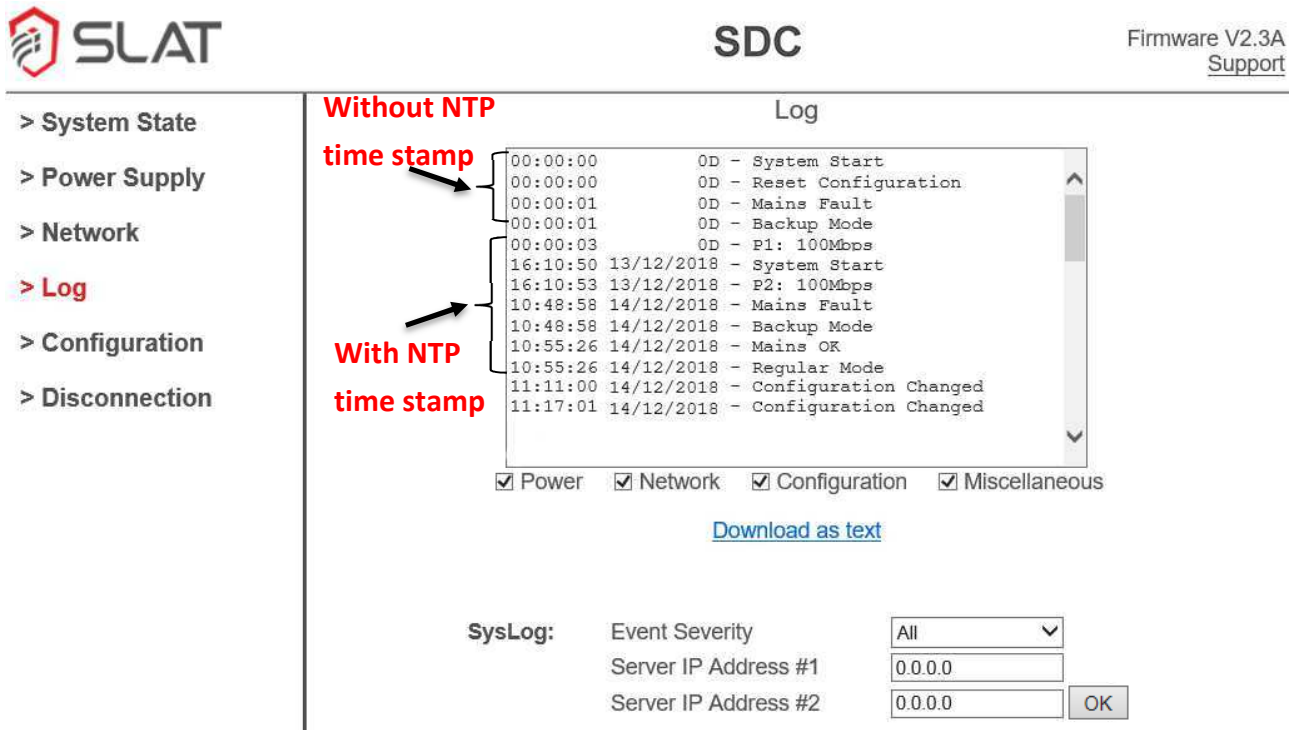

The screenshot shows the SLAT SDC interface. The top right corner displays 'Firmware V2.3A Support'. The left sidebar contains a menu with 'Log' selected. The main content area is titled 'Log' and shows a list of events. Two arrows point to the time stamps: one to '00:00:00' labeled 'Without NTP time stamp' and another to '16:10:50 13/12/2018' labeled 'With NTP time stamp'. Below the log list are checkboxes for 'Power', 'Network', 'Configuration', and 'Miscellaneous', all of which are checked. A 'Download as text' link is present. At the bottom, there is a 'SysLog:' section with fields for 'Event Severity' (set to 'All'), 'Server IP Address #1' (set to '0.0.0.0'), and 'Server IP Address #2' (set to '0.0.0.0'), along with an 'OK' button.

Figure 9.7: Log page

### 1. Time stamp

If the date and time are available via the NTP (see 6 **SNMP protocol configuration**, page19), then the events are time stamped in the following format:

```

hours : minutes : seconds   day/month/year 16:10:50 13/12/2018 - System Start
                                                16:10:53 13/12/2018 - P2: 100Mbps
Example ↻ 10:48:58 14/12/2018 - Mains Fault
                                                10:48:58 14/12/2018 - Backup Mode
                                                10:55:26 14/12/2018 - Mains OK
    
```

Otherwise, the elapsed time since the last start is used pending the availability of NTP data. In this case, the events are in the following format:

```

hours : minutes : seconds   the number of the days D 00:00:00           0D - System Start
Example ↻ 00:00:00           0D - Reset Configuration
                                                00:00:01           0D - Mains Fault
                                                00:00:01           0D - Backup Mode
                                                00:00:03           0D - P1: 100Mbps
    
```

### 2. Syslog

The product is able to send events via the UDP / 514 port to one or two syslog servers (RFC 5424 and RFC 5426). Enter the level of severity of the events to be sent and the IP address (es) of the servers.

LEVEL	DESCRIPTION	EVENT SEVERITY				
		ALL	< 5	< 4	DISABLED	
0	Emergency	System is unusable	✓	✓	✓	
1	Alert	Action must be taken immediately if necessary	✓	✓	✓	
2	Critical	Critical conditions for the system	✓	✓	✓	
3	Error	Operating error	✓	✓	✓	
4	Warning	Warning (an error can occur if no action is taken)	✓	✓		
5	Notice	Normal but significant conditions	✓			
6	Informational	Informational messages	✓			

The facility value used for the priority of SysLog messages is 1.

### 3. List of events

TYPE OF EVENTS	LEVEL OF SEVRITY	COMMENT
End of backup	0	Backup at the end of autonomy. Imminent stop.
Short Circuit	2	Short-circuit at output.
Charger Fault	2	Charger malfunction: the product needs to be changed.
Converter Fault	2	Converter malfunction: the product must be changed.
Battery Fault	2	Battery malfunction: the product must be changed.
P* - PoE Fault	3	PoE fault on port P* (overload, short circuit).
Backup Mode	4	The product operates in Backup out of Green mode.
Overload	4	Output consumption > 100% of the nominal value (current limitation to limit the output power).
Mains Fault	4	No mains
Temperature Fault	4	Internal temperature too high.
High Consumption	5	Output consumption > 95% of the nominal value.
Regular Mode	6	Normal operation on mains.
Green Mode	6	Mains present, the product is in Stealth Mode or Energy Saving Mode (ECO)
Consumption OK	6	Normal output consumption.
Stealth Request	6	Receiving an external setpoint to operate in Stealth Mode
Stop Stealth Request	6	Receiving an external setpoint to stop the Stealth Mode.
Mains OK	6	The mains is present.
Temperature OK	6	Internal temperature OK.
Charger OK	6	Proper operation of the charger.
Converter OK	6	Correct operation of the output converter.
Battery OK	6	Battery OK.
P* - PoE Halted	6	P* PoE port is stopped indeed.
P* - PoE Active	6	PoE is active: energy is supplied by P* port.
P* - PoE Standby	6	P* PoE port is ready to provide power.
P* - PoE Off	6	P* port PoE turn Off command.
P* - PoE On	6	P* port PoE turn On command.
P* - PoE Restart	6	P* port PoE restart command (stop for 8 seconds).

P\* → Port 1 to 4

Table 9.1: Events related to the power converter

TYPE OF EVENTS	LEVEL OF SEVRITY	COMMENT
Link Fault	4	Event enabled when disconnecting a port or losing an Ethernet link. The event is active until it is acknowledged. (see <b>Erreur ! Source du renvoi introuvable.</b> - Bit 26 - Ethernet failure).
Acknowledgment defect link	6	Acknowledgment of the event «Link Fault».
P* - No link	6	Ethernet link state of the port P*
P* - 10 Mbps	6	
P* - 100 Mbps	6	
P* - 1 Gbps	6	

P\* → Port 1 to 5

Table 9.2: Events related to the network

TYPE OF EVENTS	LEVEL OF SEVRITY	COMMENT
Reset Configuration	5	Reset the factory configuration (see 9.10, page 25).
Configuration Changed	6	Event generated 2 minutes after the last configuration change of the product.

Table 9.3: Events related to the configuration

TYPE OF EVENTS	LEVEL OF SEVRITY	COMMENT
System Start	5	Generated when starting or rebooting the system.

Table 9.4: Events related to the system

## 9.10 Factory configuration reset

In order to return to the original settings, a factory configuration reset has to be performed by pressing and holding the disconnect backup push button for 10 seconds, with mains power present (see Figure 6.2). The factory configuration reset concerns all user-definable parameters, including DHCP. The total Watt-hours drained and the number of power cuts, displayed on the "System State" page (see chapter 9.8) are not reset.



### **IMPORTANT REMARK!**

To perform the factory configuration reset, the product must be connected to the mains, or it will be switched off.

## 9.11 Product switch-off

To stop and switch-off the product, It's necessary to:

- Disconnect the mains power
  - Open the cover
  - Press the disconnect backup push button (see Figure 6.2)
- Or**
- Disconnect the mains power
  - Disconnect all the Ethernet ports.

## 10. Operation

During use, it is possible to interact with the product. There are two types of communication: local report and/or remote report.

### 10.1 Local report on product

#### Status LED

The product communicates its status via a Status LED on the front. Figure 6.3 in chapter 6.4 indicates the position of this LED on the product. The LED indicates the different statuses of the product by its color and state. The table explains the meanings of each state.

Color	Mode	
Green	steady	Normal mode
	slow flashing	Eco Mode or Stealth Mode
Orange	slow flashing	Backup mode
	fast flashing	Installation fault Overcurrent, short circuit Low output voltage (product overloaded) Power supply temperature too high No mains (outside specified power supply range) End of backup imminent
Red	steady	Product to be changed If no output voltage (converter fault) If product out of order (charger fault)
		Backup fault Emergency supply undervoltage Emergency supply overvoltage

Table 10.1: Status LED state

#### PoE LED

The product indicates the state of the PoE/PoE+ supply of the Ports 1 to 4 via the LEDs on the top left of each one of these ports (see Figure 6.3). When the application, which is connected to one of the ports, is supplied via PoE, the corresponding LED shines yellow.

#### Link LED

The product indicates the Ethernet connection status of an application to the Ports 1 to 4 via the LEDs on the top right of each one of these ports (see Figure 6.3). When a connection between an application and a port is established, the port's Link LED shines.

Color	Mode	
Green	steady	Connection established
	flashing	Connection established and activity on the line

Table 10.2: Link LED state

## Uplink LED

The product indicates the Ethernet connection status of Port 5 and the communication speed via the LEDs on the top left and right of this port (see Figure 6.3). When a connection on this port is established, depending on the communication speed, one of the two Uplink LEDs shines green.

Port 5 – LED right: 100 Mbps  
 Port 5 – LED left: 1 Gbps

Color	Mode
Green	steady
	flashing

Table 10.3: Uplink LED state

## 10.2 Remote report – Communication

When using the product, it is possible to communicate with it from a distance using the incorporated communication system. The Ethernet connection makes it possible to:

- retrieve information remotely,
- have more details about the types of faults,
- communicate analogue values (operating voltages and currents, remaining backup percentage, internal temperature, autonomy),
- configure the power supply.

The product communicates its information on the Ethernet connection via the HTTPS, SNMP and BACnet IP application protocols.

The information and explanations on how to configure the product are described in chapter 9.

The following chapters describe the information available via the different protocols.

### 10.2.1 Accessible data

The following data is available via SNMP and BACnet IP.

Bit	Name	Description
27 - 31	Reserve	-
26	Ethernet Failure	In read mode, if the bit is set to 1, then one or more Ethernet links have been lost. The fault remains active even if the links are restored. To acknowledge the fault, set bit to 1, which then switches to 0 in read mode.
25	Halt Stealth	Set bit to 1 to stop Stealth Mode. The bit remains set to 0 in read mode.
24	Start Stealth / Stealth State	In read mode, if the bit is set to 1, then Stealth Mode is enabled. Set bit to 1 to start Stealth Mode.
20 - 23	Reserve	-
19	Communication Failure	Internal communication failure if the bit is 1. The values of the read data are not significant.
18	Initialization Failure	Initialization of the internal communication in progress if the bit is 1. The values of the read data are not significant.
16 - 17	Reserve	-
15	High Battery Current	If the bit is set to 1, then the battery current is too high.
14	High Battery Voltage	If the bit is set to 1, the product must be replaced: the battery voltage is too high.
13	End of Autonomy	End of autonomy pre-alarm when the bit is set to 1 (imminent cut).
12	Battery Failure	If the bit is set to 1, the product must be replaced: the battery is defective or has been removed.
11	Rectifier Failure	If the bit is set to 1, the product must be replaced: the charging system is faulty and the battery may not be charged.
10	Mains Failure	If the bit is set to 1, mains power is absent.
9	Output Overload	If the bit is set to 1, the total Poe budget is exceeded.
8	Output Short-Circuit	If the bit is set to 1, the output is short-circuited.
7	High Temperature	If the bit is set to 1, the temperature in the product is too high.
6	Battery Disconnection	If the bit is set to 1, the battery is disconnected.
5	Stealth Mode or Eco Mode	If the bit is set to 1, then Stealth Mode or Eco Mode is enabled.
4	Intrusion Detection	When the option is present, if the bit is set to 1, then the box tampering and tearing detection is enabled.
0 - 3	Reserve	-

Table 10.4: Detail of the "System state" variable

Bit	Name	Description	
26 - 31	Reserve	-	
24 - 25	Ethernet State	Ethernet port status:	
		Value	Status
		00	No link
		01	10 Mbps link
		10	100 Mbps link
		11	1000 Mbps link
20 - 22	PoE Class	-	
18 - 19	PoE Management	PoE-class:	
		Value	Class
		000	Unknown
		001	1
		010	2
		011	3
		100	4
		101	- Reserve -
		110	0
		111	No class
16 - 17	PoE State	PoE control (read/write):	
		Value	Status
		00 (Write: no effect)	- Reserve -
		01	Stop PoE
		10	Start PoE
		11	Restart PoE
0 - 15	PoE Power	PoE status:	
		Value	Status
		00	PoE stopped
		01	PoE on hold
		10	PoE defective
		11	PoE active
20 - 22	PoE Class	PoE output power expressed in tenths of a Watt	

Table 10.5: Detail of the "Ethernet port X state" variable

## 10.2.2 HTTPS Protocol

The HTTPS website provides product management and data processing-related information.

Chapter 9 describes the use of the HTTPS website and the various data available.

To log onto the embedded website, use the selected login and password. Chapter 9.5 explains how to change the password.

### 10.2.3 SNMP Protocol

2 MIBs are available over SNMP:

- The **MIB-2**, defined by the RFC1213 standard.
- The **MIB SLAT-SDC** is proprietary and specific to SLAT. It is common to the entire Safe DC range. It can be downloaded from the embedded website (HTTPS) on the "Network" page (see chapter 9.6).



**IMPORTANT REMARK!**

For the SNMP v1 et v2c The Write Community is “private”.

For the SNMP v3 the user and the password must be configured.

The following variables are available via SNMP:

<u>Mib-2</u>		
Variable	SNMP Name	Description
Model	sysDesc	SDC reference and version.
System name	sysName	SDC system name (available in write mode, up to 16 characters)
Location	sysLocation	SDC location (available in write mode, up to 32 characters)

Table 10.6: MIB-2 variables

<b>Mib SLAT</b>		
<b>Variable</b>	<b>SNMP Name</b>	<b>Description</b>
Model	model	SDC reference and version.
Capacity	capacity	Battery capacity: energy expressed in Watt-hours.
Serial number	serialNumber	SDC serial number.
System state	systemState	32-bit variable presenting the state of the SDC system. Each time a change is made, this variable is sent in the form of an SNMP trap (for details of the variable, see Table 10.4) *.
Gauge	energyGauge	Gauge in percent, corresponding to the amount of energy available in the battery. A value of 100 corresponds to a fully charged battery.
Output voltage	outputVoltage	Output voltage: the value is expressed in tenths of a Volt.
Output current:	outputCurrent	Output current: the value is expressed in tenths of an Ampere.
Output power	outputPower	Instantaneous power supplied by the SDC: the value is expressed in Watts.
Mains power	mainsPower	Instantaneous mains power input: the value is expressed in Watts.
Temperature	temperature	SDC internal temperature: the value is expressed in °C.
Total discharged energy	totalDischargedEnergy	Amount of energy provided by the SDC battery since initial commissioning: the value is expressed in tenths of a Watt-hour.
Mains cut total number	mainsCutTotalNumber	Total number of power cuts since initial commissioning.
Output voltage adjustment	voutAdjust	Not applicable for SDC-PoE products.
Stealth Mode threshold	stealthModeThreshold	Minimum battery charge level in percent for Stealth Mode. Accepted values: 25, 50, 75 or 100. The value 100 disables the Stealth Mode.
Eco Mode threshold	ecoModeThreshold	Minimum battery charge level in percent for Eco Mode. Accepted values: 50, 60, 70, 80 or 100. The value 100 disables Eco Mode.
Ethernet port X state	ethernetPortX-State	32-bit variable presenting the status of each Ethernet port X representing the number of port (for details of this variable, see Table 10.5).

Table 10.7: MIB SLAT variables

\* To use SNMP traps, the IP addresses of the SNMP servers to which the traps should be sent must be entered into the HTTPS website (see chapter 9.6).

## 10.2.4 BACnet IP Protocol

The following objects are accessible via BACnet IP:

Property	Remark / Value	RW
Object_Identifier	Product instance, by default: 421000	RW-E
Object_Name	SDC system name (max. 16 characters). By default: ""	RW-E
Object_Type	DEVICE (8)	R
System_Status	OPERATIONAL (0) or STATUS_NON_OPERATIONAL (4) if not ready	R
Vendor_Name	"SLAT"	R
Vendor_Identifier	954	R
Model_Name	Product type	R
Location	Product location (max. 32 characters). By default: ""	RW-E
Firmware_Revision	"Communication firmware version"	R
Application_Software_Version	""	R
Protocol_Version	1	R
Protocol_Revision	12	R
Protocol_Services_Supported	read-property, write-property, who-has, who-is, device-communication control	R
Protocol_Object_Types_Supported	DEVICE, ANALOG_VALUE, POSITIVE_INTEGER_VALUE	R
Object_List [17]	device, analog-value 0 ...10, positive_integer_value 0...4	R
Max_APDU_Length_Accepted	1476	R
Segmentation_Supported	NO_SEGMENTATION (3)	R
APDU_Timeout	3000	R
Number_Of_APDU_Retries	3	R
Device_Address_Binding	-	R
Database_Revision	0	R
Serial_Number	Serial number	R
R: Read Property, W: Write Property, -E: Storage in EEPROM / Flash		

Table 10.8: BACnet IP variables

Analog Value Object 0		
Property	Remark / Value	RW
Object_Identifier	analog-value 0	R
Object_Name	"Vout"	R
Object_Type	ANALOG_VALUE (2)	R
Description	"Output Voltage"	R
Present_Value	Output Voltage	R
Status_Flags	IN_ALARM: 0	R
	FAULT: 0	
	OVERRIDDEN: 0	
	OUT_OF_SERVICE: 0	
Event_State	NORMAL (0)	R
Out_Of_Service	FALSE (0)	R
Units	Volts (5)	R
R: Read Property, W: Write Property, -E: Storage in EEPROM / Flash		

Table 10.9: Analog Value Object 0

Analog Value Object 1		
Property	Remark / Value	RW
Object_Identifier	analog-value 1	R
Object_Name	"Iout"	R
Object_Type	ANALOG_VALUE (2)	R
Description	"Output current"	R
Present_Value	Output current	R
Status_Flags	IN_ALARM: 0	R
	FAULT: 0	
	OVERRIDDEN: 0	
	OUT_OF_SERVICE: 0	
Event_State	NORMAL (0)	R
Out_Of_Service	FALSE (0)	R
Units	Amperes (3)	R
R: Read Property, W: Write Property, -E: Storage in EEPROM / Flash		

Table 10.10: Analog Value Object 1

Analog Value Object 2		
Property	Remark / Value	RW
Object_Identifier	analog-value 2	R
Object_Name	"Pout"	R
Object_Type	ANALOG_VALUE (2)	R
Description	"Output power"	R
Present_Value	Output power	R
Status_Flags	IN_ALARM: 0	R
	FAULT: 0	
	OVERRIDDEN: 0	
	OUT_OF_SERVICE: 0	
Event_State	NORMAL (0)	R
Out_Of_Service	FALSE (0)	R
Units	Watts (47)	R
R: Read Property, W: Write Property, -E: Storage in EEPROM / Flash		

Table 10.11: Analog Value Object 2

Analog Value Object 3		
Property	Remark / Value	RW
Object_Identifier	analog-value 3	R
Object_Name	"Pin"	R
Object_Type	ANALOG_VALUE (2)	R
Description	"Input power"	R
Present_Value	Mains power	R
Status_Flags	IN_ALARM: 0	R
	FAULT: 0	
	OVERRIDDEN: 0	
	OUT_OF_SERVICE: 0	
Event_State	NORMAL (0)	R
Out_Of_Service	FALSE (0)	R
Units	Watts (47)	R
R: Read Property, W: Write Property, -E: Storage in EEPROM / Flash		

Table 10.12: Analog Value Object 3

Analog Value Object 4		
Property	Remark / Value	RW
Object_Identifier	analog-value 4	R
Object_Name	"Temperature"	R
Object_Type	ANALOG_VALUE (2)	R
Description	"Internal temperature"	R
Present_Value	Internal temperature	R
Status_Flags	IN_ALARM: 0	R
	FAULT: 0	
	OVERRIDDEN: 0	
	OUT_OF_SERVICE: 0	
Event_State	NORMAL (0)	R
Out_Of_Service	FALSE (0)	R
Units	Degree Celsius (62)	R
R: Read Property, W: Write Property, -E: Storage in EEPROM / Flash		

Table 10.13: Analog Value Object 4

Analog Value Object 5		
Property	Remark / Value	RW
Object_Identifier	analog-value 5	R
Object_Name	"BatteryGauge"	R
Object_Type	ANALOG_VALUE (2)	R
Description	"Remaining autonomy"	R
Present_Value	Battery gauge	R
Status_Flags	IN_ALARM: 0	R
	FAULT: 0	
	OVERRIDDEN: 0	
	OUT_OF_SERVICE: 0	
Event_State	NORMAL (0)	R
Out_Of_Service	FALSE (0)	R
Units	Percent (98)	R
R: Read Property, W: Write Property, -E: Storage in EEPROM / Flash		

Table 10.14: Analog Value Object 5

Analog Value Object 6		
Property	Remark / Value	RW
Object_Identifier	analog-value 6	R
Object_Name	"Battery capacity"	R
Object_Type	ANALOG_VALUE (2)	R
Description	"Installed battery capacity"	R
Present_Value	Battery capacity	R
Status_Flags	IN_ALARM: 0	R
	FAULT: 0	
	OVERRIDDEN: 0	
	OUT_OF_SERVICE: 0	
Event_State	NORMAL (0)	R
Out_Of_Service	FALSE (0)	R
Units	Watt hours (18)	R
R: Read Property, W: Write Property, -E: Storage in EEPROM / Flash		

Table 10.15: Analog Value Object 6

Analog Value Object 7		
Property	Remark / Value	RW
Object_Identifier	analog-value 7	R
Object_Name	"StealthModeThreshold"	R
Object_Type	ANALOG_VALUE (2)	R
Description	"Minimum battery gauge level for Stealth Mode (25%, 50% or 75% - 100 disables Stealth Mode)"	R
Present_Value	Stealth Mode threshold	RW-E
Status_Flags	IN_ALARM: 0	R
	FAULT: 0	
	OVERRIDDEN: 0	
	OUT_OF_SERVICE: 0	
Event_State	NORMAL (0)	R
Out_Of_Service	FALSE (0)	R
Units	Percent (98)	R
R: Read Property, W: Write Property, -E: Storage in EEPROM / Flash		

Table 10.16: Analog Value Object 7

Analog Value Object 8		
Property	Remark / Value	RW
Object_Identifier	analog-value 8	R
Object_Name	"EcoModeThreshold"	R
Object_Type	ANALOG_VALUE (2)	R
Description	"Minimum battery gauge level for Eco Mode (50%, 60%, 70% or 80% - 100% disables Eco Mode)"	R
Present_Value	Eco Mode threshold	RW-E
Status_Flags	IN_ALARM: 0	R
	FAULT: 0	
	OVERRIDDEN: 0	
	OUT_OF_SERVICE: 0	
Event_State	NORMAL (0)	R
Out_Of_Service	FALSE (0)	R
Units	Percent (98)	R
R: Read Property, W: Write Property, -E: Storage in EEPROM / Flash		

Table 10.17: Analog Value Object 8

Analog Value Object 9		
Property	Remark / Value	RW
Object_Identifier	analog-value 9	R
Object_Name	"TotalDischargedEnergy"	R
Object_Type	ANALOG_VALUE (2)	R
Description	"Total discharged energy"	R
Present_Value	Total discharged energy	R
Status_Flags	IN_ALARM: 0	R
	FAULT: 0	
	OVERRIDDEN: 0	
	OUT_OF_SERVICE: 0	
Event_State	NORMAL (0)	R
Out_Of_Service	FALSE (0)	R
Units	Watt hours (18)	R
R: Read Property, W: Write Property, -E: Storage in EEPROM / Flash		

Table 10.18: Analog Value Object 9

Analog Value Object 10		
Property	Remark / Value	RW
Object_Identifier	analog-value 10	R
Object_Name	"MainsCut"	R
Object_Type	ANALOG_VALUE (2)	R
Description	"Mains cut total number"	R
Present_Value	Total number of power cuts	R
Status_Flags	IN_ALARM: 0	R
	FAULT: 0	
	OVERRIDDEN: 0	
	OUT_OF_SERVICE: 0	
Event_State	NORMAL (0)	R
Out_Of_Service	FALSE (0)	R
Units	No units (95)	R
R: Read Property, W: Write Property, -E: Storage in EEPROM / Flash		

Table 10.19: Analog Value Object 10

Positive Integer Value Object 0		
Property	Remark / Value	RW
Object_Identifier	positive-integer-value 0	R
Object_Name	"Default"	R
Object_Type	POSITIVE_INTEGER_VALUE (48)	R
Description	"System state register"	R
Present_Value	System state [32 bit]*	R
Status_Flags	IN_ALARM: 0	R
	FAULT: 0	
	OVERRIDDEN: 0	
	OUT_OF_SERVICE: 0	
Units	No units (95)	R
R: Read Property, W: Write Property, -E: Storage in EEPROM / Flash		

Table 10.20: Positive Integer Value Object 0

\*To consult the detail of the "Present Value – System state" see Table 10.4.

Positive Integer Value Object 1		
Property	Remark / Value	RW
Object_Identifier	positive-integer-value 1	R
Object_Name	"StealthMode"	R
Object_Type	POSITIVE_INTEGER_VALUE (48)	R
Description	"Stealth mode operating"	R
Present_Value	Stealth Mode disabled if null, else enabled	RW
Status_Flags	IN_ALARM: 0	R
	FAULT: 0	
	OVERRIDDEN: 0	
	OUT_OF_SERVICE: 0	
Units	No units (95)	R
R: Read Property, W: Write Property, -E: Storage in EEPROM / Flash		

Table 10.21: Positive Integer Value Object 1

Positive Integer Value Object 2		
Property	Remark / Value	RW
Object_Identifier	positive-integer-value 2	R
Object_Name	"SerialNumber"	R
Object_Type	POSITIVE_INTEGER_VALUE (48)	R
Description	"Serial number"	R
Present_Value	Serial number	R
Status_Flags	IN_ALARM: 0	R
	FAULT: 0	
	OVERRIDDEN: 0	
	OUT_OF_SERVICE: 0	
Units	No units (95)	R
R: Read Property, W: Write Property, -E: Storage in EEPROM / Flash		

Table 10.22: Positive Integer Value Object 2

Positive Integer Value Object 3		
Property	Remark / Value	RW
Object_Identifier	positive-integer-value 3	R
Object_Name	"Ethernet1"	R
Object_Type	POSITIVE_INTEGER_VALUE (48)	R
Description	"1st Ethernet port state"	R
Present_Value	Port 1 status *	R
Status_Flags	IN_ALARM: 0	R
	FAULT: 0	
	OVERRIDDEN: 0	
	OUT_OF_SERVICE: 0	
Units	No units (95)	R
R: Read Property, W: Write Property, -E: Storage in EEPROM / Flash		

Table 10.23: Positive Integer Value Object 3

\*To consult the detail of the "Present Value - Port 1 status" see Table 10.5.

Positive Integer Value Object 4		
Property	Remark / Value	RW
Object_Identifier	positive-integer-value 4	R
Object_Name	"Ethernet2"	R
Object_Type	POSITIVE_INTEGER_VALUE (48)	R
Description	"2nd Ethernet port state"	R
Present_Value	Port 2 status *	R
Status_Flags	IN_ALARM: 0	R
	FAULT: 0	
	OVERRIDDEN: 0	
	OUT_OF_SERVICE: 0	
Units	No units (95)	R
R: Read Property, W: Write Property, -E: Storage in EEPROM / Flash		

Table 10.24: Positive Integer Value Object 4

To consult the detail of the "Present Value - Port 2 status" see Table 10.5.

Positive Integer Value Object 5		
Property	Remark / Value	RW
Object_Identifier	positive-integer-value 5	R
Object_Name	"Ethernet3"	R
Object_Type	POSITIVE_INTEGER_VALUE (48)	R
Description	"3rd Ethernet port state"	R
Present_Value	Port 3 status *	R
Status_Flags	IN_ALARM: 0	R
	FAULT: 0	
	OVERRIDDEN: 0	
	OUT_OF_SERVICE: 0	
Units	No units (95)	R
R: Read Property, W: Write Property, -E: Storage in EEPROM / Flash		

Table 10.25: Positive Integer Value Object 5

To consult the detail of the "Present Value - Port 3 status" see Table 10.5.

Positive Integer Value Object 6		
Property	Remark / Value	RW
Object_Identifier	positive-integer-value 6	R
Object_Name	"Ethernet4"	R
Object_Type	POSITIVE_INTEGER_VALUE (48)	R
Description	"4th Ethernet port state"	R
Present_Value	Port 4 status *	R
Status_Flags	IN_ALARM: 0	R
	FAULT: 0	
	OVERRIDDEN: 0	
	OUT_OF_SERVICE: 0	
Units	No units (95)	R
R: Read Property, W: Write Property, -E: Storage in EEPROM / Flash		

Table 10.26: Positive Integer Value Object 6

To consult the detail of the "Present Value - Port 4 status" see Table 10.5.

Positive Integer Value Object 7		
Property	Remark / Value	RW
Object_Identifier	positive-integer-value 7	R
Object_Name	"Ethernet5"	R
Object_Type	POSITIVE_INTEGER_VALUE (48)	R
Description	"5th Ethernet port state"	R
Present_Value	Port 5 status *	R
Status_Flags	IN_ALARM: 0	R
	FAULT: 0	
	OVERRIDDEN: 0	
	OUT_OF_SERVICE: 0	
Units	No units (95)	R
R: Read Property, W: Write Property, -E: Storage in EEPROM / Flash		

Table 10.27: Positive Integer Value Object 7

To consult the detail of the "Present Value - Port 5 status" see Table 10.5.

## 11. Maintenance and troubleshooting

---

### Maintenance

The product has been designed to function for a long period of time without requiring maintenance. To ensure the best level of service, it is essential to install it in a dry dust-free location.

For a proper functioning of the product, it is necessary to ensure that the ventilation grilles are dust-free.

## Troubleshooting

During installation, commissioning or use, unexpected situations may arise. In the event of a problem, the table below can be consulted. It contains a list of possible problems with their corresponding causes and solutions.

Problem	Fault via communication	Cause	Solution
The product does not start. The <i>Status LED</i> remains off.	No communication	The mains voltage is not connected or is not present.	Check if the mains voltage is connected properly.
		The mains voltage fuse is faulty or absent.	Replace the product.
The <i>Status LED</i> is orange + fast flashing and there is no voltage at the output.	Output short-circuit	Output overload or short-circuit.	Remove the short-circuit.
The <i>Status LED</i> is red. The output voltage is OK.	Backup fault	Backup malfunction; the backup is disconnected or has failed.	Replace the product.
	Charger fault	Charger malfunction.	The charger has failed. Replace the product.
The <i>Status LED</i> is orange + fast flashing and the output voltage is less than the normal value.	Output overload	There is a slight overload on the output.	Lower the output load until the current is less than the maximum output value (see Table 12.4).
The <i>Status LED</i> is orange + fast flashing and the output voltage is OK.	Temperature too high	Temperature is too high because the ambient temperature does not fulfil the conditions specified in Table 12.6.	Cool the installation.
		The air intake is blocked.	Clean the blocked air intake.
The product's IP address is lost.	No communication	-	Perform a factory configuration reset (see chapter 9.10).
The administrator's password has been lost.	No communication	-	Perform a factory configuration reset (see chapter 9.10).
A user password has been lost.	No communication	-	Delete the account of the user via the administrator's account.
No connection: The <i>Link LED</i> of the Port 1 to 4 and the <i>Uplink LEDs</i> of the Port 5 are not illuminated.	No communication	Bad Ethernet connection.	Verify the connection and use an appropriate Ethernet cable (see Table 8.1).
Recurrent loss of connection: Ethernet Link/Act LED on ports 1 and/or 2 turn off regularly	Communication interrupted regularly	Green Ethernet compatibility issue	Disable Green Ethernet (chapitre 9.6, page 17).
The <i>Status LED</i> and one <i>Link LED</i> or <i>Uplink LED</i> are illuminated but there is no communication.	No communication	Configuration problem.	Check that the configuration of the SDC and the computer are compatible (see chapter 9).

Table 11.1: Problems, causes and solutions

For additional technical assistance, contact the SLAT hotline +33 4 78 66 63 70.

For an RMA request (authorization to return goods), refer to chapter 0 .

No equipment may be returned without prior issuance of an RMA number.

## 12. Technical data

### 12.1 Electrical characteristics

#### 12.1.1 Electrical characteristics of the power supply

Mains input	
AC network voltage	99 V ... 264 V
DC network voltage	140 V ... 375 V
Frequency	45 Hz ... 65 Hz
Class	1
Inrush current	Limited by CTN
Neutral system	TT, TN, IT
Primary short-circuit protection	Slow-blow fuse on the phase
Characteristics of built-in fuse	2.5 A (slow-blow, internal)
Shock wave protection	Differential mode by varistor and filter
Primary current @ 99 V	1.5 A
Primary current @ 264 V	0.38 A
Residual consumption in Eco and Stealth Mode	< 1 W
Circuit breaker to be provided upstream	Curve C or D (recommended rating 2 A)

Table 12.1: Mains input electrical characteristics

#### Current behavior:

##### Inrush current at start-up

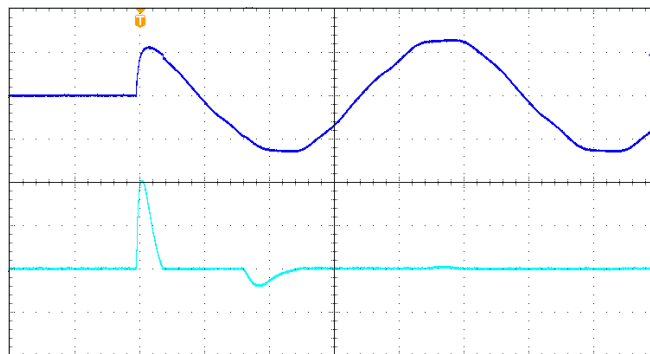

Figure 12.1: Oscillogram - inrush current

Test conditions	
Input voltage	240 V AC
Output current and voltage	12 V DC; no load
Ambient temperature	+20°C
Description of the diagram	
Upper curve	Input voltage (250 V / DIV)
Lower curve	Input current (20 A / DIV)
Time scale	4 ms / DIV

Table 12.2: Description of the oscillogram - inrush current

Start-up sequencing

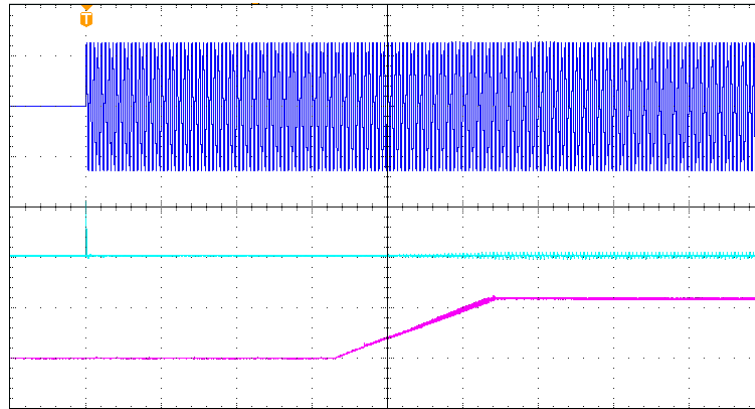

Figure 12.2: Oscillogram - starting behavior

Test conditions	
Input voltage	240 V AC
Output current and voltage	12 V DC; 4.5 A
Ambient temperature	+20°C
Description of the diagram	
Upper curve	Input voltage (250 V / DIV)
Medium curve	Input current (20 A / DIV)
Lower curve	Output voltage (50 V / DIV)
Time scale	400 ms / DIV

Table 12.3: Description of the oscillogram - starting behavior

### 12.1.2 Electrical output characteristics

Output	
Standards	IEEE 802.3af, IEEE 802.3at
Rated voltage $U_n$	55 V
Voltage precision	1%
Available output power	60 W
Power limitation	from $P_{max}$ to $P_{max}+10\%$ for output voltage > 6 V
HF ripple peak-peak (20 MHz-50 $\Omega$ )	< 1.9% of $U_n$
Effective LF ripple	< 0.3% of $U_n$
Static and dynamic regulation characteristics	< 7% of $U_n$ for cumulative variations of the mains and the load (from 10 to 90%)
Protection	electronic (no fuse)
$\eta$ @ 20% of use load	90%
$\eta$ @ 75% of use load	93%
$\eta$ @ 100% of use load	92%
Protection against output short-circuit	by power supply cut with cyclical restart
Protection against surges in user output	deregulation or connection error, by cut-off with cyclical restart if output voltage > $U_n + 10\%$
Short-circuit if	$U_{output} < 6 V$ or $I > 30 A$

Table 12.4: Electrical output characteristics

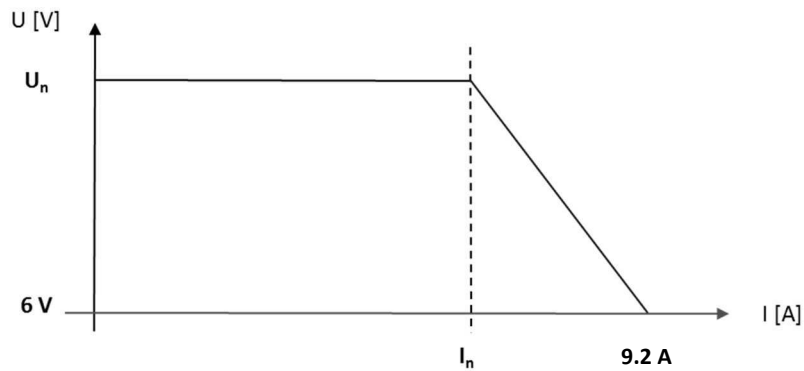

Figure 12.3: Output voltage vs User current

## 12.2 Functional characteristics

Four PoE Ethernet ports permanently supply (after negotiation) a constant voltage (55 V) to the equipment which has to be powered. In the event of a current break, the built-in backup maintains the electrical power supply of the equipment connected to the product for the duration defined when the SDC-PoE4 was chosen.

An Ethernet connection allows to retrieve the information including the analogue values remotely (voltages and load current, backup, autonomy, internal electronic temperature).

By default, the DHCP is active. The HTTPS webserver makes it possible amongst others to configure the communication parameters and to choose the functioning mode.

There are also one Status LED on the front, one LED for the Ethernet state (Link LED) and one PoE LED per PoE port as well as two LEDs for the Ethernet state (Uplink LED) of the uplink port available.

The Stealth Mode function makes it possible to shed load from the network while guaranteeing backup autonomy.

## 12.3 Mechanical characteristics

Mechanical specifications	
Envelope	ABS
Protection rating	IP20 (floor-mounted) or IP30 (fixed to wall)
Size	W 285 x H 198 x D 61 mm
Weight	1.1 kg (backup D) / 1.3 kg (backup E)
Installation	Box to be floor-mounted or fixed to a wall

Table 12.5: Mechanical specifications

## 12.4 Environmental specifications

Environmental specifications		
Storage temperature		-25 ... +60°C
Operating temperature	in emergency supply or normal mode	-10 ... +55°C
	in battery charging mode	-5 ... +55°C
Relative humidity	in storage	10 ... 95%
	operating	20 ... 95%
Altitude	Above 2,000 m, the temperature maximum decreases by 5% every 1,000 m.	

Table 12.6: Environmental specifications

## 12.5 Standards

The product is designed to meet with LV and EMC directives (immunity and emission). It complies with the following standards.

### 12.5.1 Safety standards

Section	Standard number	Title/Content
LVD Safety	EN 62368-1 (2020)	Audio/video, information and communication technology equipment - Part 1: Safety requirements.
LVD Safety	EN 62368-3 (2020)	Audio/video, information and communication technology equipment - Part 3: Safety aspects relating to the transfer of d.c. power through communication cables and accesses

Table 12.7: Safety standards

### 12.5.2 EMC standards

Section	Standard number	Title/Content
Immunity	EN 61000-6-1 (March 2007)	Immunity for residential, commercial and light-industrial environments (generic standard)
Immunity	EN 61000-6-2 (January 2006)	Immunity standard for industrial environments (generic standard)
Emissions	EN 61000-3-2 (August 2006) (class A)	Limits for harmonic current emissions (equipment input current $\leq$ 16 A per phase)
Emissions	EN 61000-6-3 (March 2007)	Emission standard for residential, commercial and light-industrial environments (generic standard)
Emissions	EN 61000-6-4 (March 2007)	Emission standard for industrial environments (generic standard)
Emissions	EN 55032 (2015) (class B)	Electromagnetic compatibility of multimedia equipment

Table 12.8: EMC standards

### 12.5.3 IEEE standards

The voltage is factory set so that the output voltage is conform with the standards IEEE 802.3af and IEEE 802.3at.

## 13. Warranty and Product Returns

---

### 13.1 Warranty

The equipment is guaranteed for three years from the date of delivery (ex-works). It is strictly limited to reimbursement or replacement (at our discretion and without compensation of any sort) of parts recognized as faulty by our services, following the return of the product to our premises at the buyer's expense. The replacement or repair of equipment is possible only on our premises. In order to allow our customers to benefit from the latest technical improvements, SLAT reserves the right to make all necessary modifications to its products.



### 13.2 Product Returns

#### 13.2.1 Product under warranty

For the maintenance of your products under warranty, SLAT offer the best solution to facilitate your repairs and minimize lead times:

- Contact the Customer Service department using the form available on our web site [www.slat.com](http://www.slat.com) , taking care to fill in all the required fields.
- The RMA form will be processed and sent back by the SLAT account manager.
- After receiving your RMA form, return two copies with your product(s), one INSIDE the package and the other on the OUTSIDE of the package for warehouse identification purposes, thereby guaranteeing traceability of your product.
- The repaired or replaced product(s) will be returned within a maximum of 15 business days.

### 13.2.2 Product not under warranty

#### Product repair by SLAT

Contact Customer Service at [service.client@slat.fr](mailto:service.client@slat.fr), making sure to provide all of the following information:

- Last name/First Name
- Company / Complete Address / Phone / Email
- Exact model of the product (indicated on the product label) / SLAT reference (indicated on the product label, code number) / Serial No. / Quantity / Problems(s) encountered (describe the faults encountered with the product)

The form to request the RMA number is also available at [www.slat.com](http://www.slat.com).

The account manager will send the RMA form by email together with a quote according to the relevant product range.

After receiving your RMA form, return two copies with your product(s), one INSIDE the package and the other on the OUTSIDE of the package for warehouse identification purposes, thereby guaranteeing traceability of your product. The repairs will be made only after the receipt of the accepted quote together with the repair order form. If the quote is rejected, please return it to [service.client@slat.fr](mailto:service.client@slat.fr) marked "refused" and specify whether the equipment should be destroyed or returned in its existing condition (in this case a charge of €150 will be invoiced for handling costs).

The repaired or replaced product(s) will be returned within a maximum of 15 business days. A new 3 month warranty is attributed to the relevant product.

**Conditions: Authorization to return products is issued by SLAT.**

**An RMA number is assigned to each product to be returned. Each RMA number is valid for 30 days.**

**No equipment may be returned without prior issuance of an RMA number.**



SLAT

11, Rue Jean Elysée Dupuy BP66  
69543 Champagne au Mont d'Or Cedex  
FRANCE

Tel.: +33 478 66 63 60

Fax: +33 478 47 54 33

e-mail: [comm@slat.fr](mailto:comm@slat.fr)

SLAT GmbH

Leitzstraße 45  
70469 Stuttgart  
DEUTSCHLAND

Tel.: +49 711 899 890 08

Fax: +49 711 899 890 90

E-mail: [info@slat-gmbh.de](mailto:info@slat-gmbh.de)



[www.slat.com](http://www.slat.com)