

Safe DC SDC-PoE8

8 ports Switch - PoE/PoE+/HiPoE/SFP
integrated Micro-UPS



BACnet IP / HTTPS / SNMP



EN Operating Instructions

1. Safety	3
2. Directives and environment and public health protection	4
3. Definition of the symbols	4
4. General Information	5
4.1 The company	5
4.2 Purpose of the document	5
4.3 Related documentation	5
4.4 Intended audience	5
4.5 Indicator labels	6
5. The product	7
5.1 Description	7
5.2 Operating principle	7
5.3 Schematic diagram	8
5.4 Product view	9
5.5 Scope of delivery	10
6. Energy storage	11
6.1 Available storage option	11
6.2 Technology	11
6.3 Autonomy curves	12
6.4 Autonomy duration	12
7. Installation	13
7.1 Positioning / Installation on support	13
7.2 Connection	14
7.2.1 Connection specifications	14
7.2.2 Wiring	14
8. Commissioning	17
8.1 Communication protocols	17
8.2 Assigning an IP address	17
8.3 Login page – Logging onto the product	18
8.4 Web-based user interface – Description	18
8.4.1 Headline	19
8.4.2 Main menu	19
8.4.3 Main screen	19
8.5 Configuration and operation of the switch	19
8.6 Reboot device	20
8.7 Factory configuration reset	20
8.8 Product switch-off	20

9. Operation	21
9.1 Local report on product	21
9.2 Input fault and alarms report by dry contact	22
9.2.1 Input fault by dry contact (Digital Input)	22
9.2.2 Alarms report by dry contact NC	22
9.3 Remote report – Communication	22
9.3.1 Accessible data	23
9.3.2 HTTPS Protocol	24
9.3.3 SNMP Protocol	25
9.3.4 BACnet IP Protocol	27
10. Maintenance and troubleshooting	36
11. Technical data	38
11.1 Electrical characteristics	38
11.1.1 Electrical characteristics of the power supply	38
11.1.2 Electrical output characteristics	39
11.1.3 Functional characteristics	39
11.2 Mechanical characteristics	40
11.3 Environmental specifications	40
11.4 Standards	40
11.4.1 Safety standards	40
11.4.2 EMC standards	41
11.4.1 IEEE standards	41
11.4.2 Transportation standards	41
12. Warranty and Product Returns	42
12.1 Warranty	42
12.2 Product Returns	42
12.2.1 Product under warranty	42
12.2.2 Product not under warranty	43

1. Safety

These operating instructions contain all the instructions to follow in order to install, commission and operate the switch **SDC-PoE8** with integrated emergency power supply. It is recommended to follow them very carefully to ensure an optimum functioning of the product.

It is vital to read the Safety Precautions before installing or starting to operate this product.

SAFETY PRECAUTIONS:

SDC-PoE8 is an equipment designed to be connected to the public 230 VAC mains network. It must not be installed outdoors. It ensures power supply and continuity of service for applications in the event of power failure. The lithium backup function is integrated into the product.

- An easily accessible two-pole circuit-breaker has to be installed upstream.
- To avoid any risk of electric shock, all **INTERVENTIONS** must be carried out with the equipment **SWITCHED OFF** (upstream two-pole circuit-breaker open).
- The operation must be performed by qualified personnel only.
- During installation connect the ground wire first and disconnect it last when dismantling.
- The equipment is to be installed to DIN rail.
- The equipment is only designed to be used in an enclosure with restricted access (IP30 control cabinet), and to be installed on a concrete surface or any other non-combustible surface.
- Size cables according to the maximum input/output current ($\geq 0,15 \text{ mm}^2/\text{A}$).
- The product can be installed vertically.
- Mount the appliance in a vertical position.
- Ensure sufficient convection (minimum top and bottom clearance space 30 mm).
- Observe the thermal and mechanical limits.
- Provided Battery is Li-ion type.
- Caution ! There is a risk of explosion if the battery is replaced by a wrong model.
- The backup is maintenance-free. Do not open it.
In the event of prolonged storage or disconnection, disconnect the mains and the network cables from the product and wait 1 minute until the product stops.
- When used, recycle product and battery according to instructions.
- Indoor use only.
- EN 62368-1 conformity (This equipment is not suitable for use in locations where children are likely to be present).
- Clean the cabinet with a soft rag.

2. Directives and environment and public health protection

The SLAT company is, through their products, committed to protecting the environment and the public health and complies with the corresponding directives.

SLAT develops and manufactures all its products in accordance with the environmental directives RoHS (Restriction of Hazardous Substances) and WEEE (Waste of Electrical and Electronic Equipment).



Restriction
of Hazardous
Substances



At its end of life, the product has to be recycled. For end-of-life recycling, a plug-in connector enables qualified professionals independent from SLAT to easily remove the backup.



The SLAT products are compliant with the CE directives. The CE mark dates to 2018.



3. Definition of the symbols



Conformity of the product with the requirements of the European directives.



WEEE (Waste of Electrical and Electronic Equipment)
Disposal of the product in an appropriate collection and recycling structure.
This product should not be disposed of with household waste.



RoHS (Restriction of Hazardous Substances)
Compliance with the European Directive restricting the use of certain hazardous substances in electrical and electronic equipment.

4. General Information

4.1 The company

To meet its customers' requirements more effectively:

- SLAT has been designing and manufacturing all its products in accordance with the ISO 14001 standard v15.
- SLAT recycles its products at the end of their life cycle, by means of its recycling program.

4.2 Purpose of the document

The operating instructions provide the information necessary for the positioning, the connection, the configuration and the operation of the **SDC-PoE8** equipment.

These instructions are also available in PDF format in MySLAT at www.slat.com.

4.3 Related documentation

The following documents are associated with these operating instructions:

- Installation manual
- Commercial brochure
- Datasheet
- Advanced user's manual (MySLAT at www.slat.com)

This documentation is available at www.slat.com.

4.4 Intended audience

The operations described in this document should be performed only by authorized trained staff.

4.5 Indicator labels

This document comprises three types of important notices.

The type of notice informs you of the potential consequences in the case of non-compliance with the instructions.

These consequences are not exhaustive and are sorted in order of ascending risk:



IMPORTANT REMARK!

Contains additional information. Non-compliance will not cause damage to equipment or personal injuries.



CAUTION!

Equipment and goods can be seriously damaged or people seriously injured if the precautions for use are not followed.



DANGER!

Non-compliance may result in serious injury or death.

5. The product

5.1 Description

8 port switch (PoE/PoE+/HiPoE) with lead and cadmium-free "Smart Backup Inside" with very long service life

The **SDC-PoE8** is a managed 8-port PoE switch with an integrated emergency power supply (UPS DC). With a combination of PoE ports and fiber ports, the switch handles the data flow from the connected applications. The product is designed to meet the specific needs of technical IP networks (video surveillance, WiFi, technical building management, etc.).

It provides continuous power and backup power to the connected PoE applications and protects the data transmission from the connected applications to the supervisor even in the event of power failure or brownout by means of the built-in backup power supply. The batteries integrated in the switch are Li-ion technology "LiFePO₄".



5.2 Operating principle

Switch function

After setting up the switch's functioning via the embedded web interface, the switch SDC-PoE8 handles the data flow from the connected devices.

It improves the availability of the critical applications, protects the sensitive information and optimizes the network bandwidth to deliver information from the applications more efficiently.

With the layer 2 features, the switch provides a better manageability, security, QoS and performance. The switch's features include amongst others VLAN, Spanning Tree, Mirroring, Port isolation, IGMP Snooping, DHCP Snooping, LLDP, POE+/HiPoE management, IP Source Guard, ARP inspection and ACLs.

Emergency power supply function

When the network is present, the SDC-PoE8 switch continuously supplies power to the connected PoE devices (PD: Powered Device) via the PoE/PoE+/HiPoE ports and keeps the battery charged.

When the mains fail, the built-in emergency supply continues to provide power to the connected devices without interruption.

In the event of a complete discharge, the recharging time to 100% of the backup will in all cases be less than 20 hours of mains presence.

5.3 Schematic diagram

The visual below shows the product diagram:

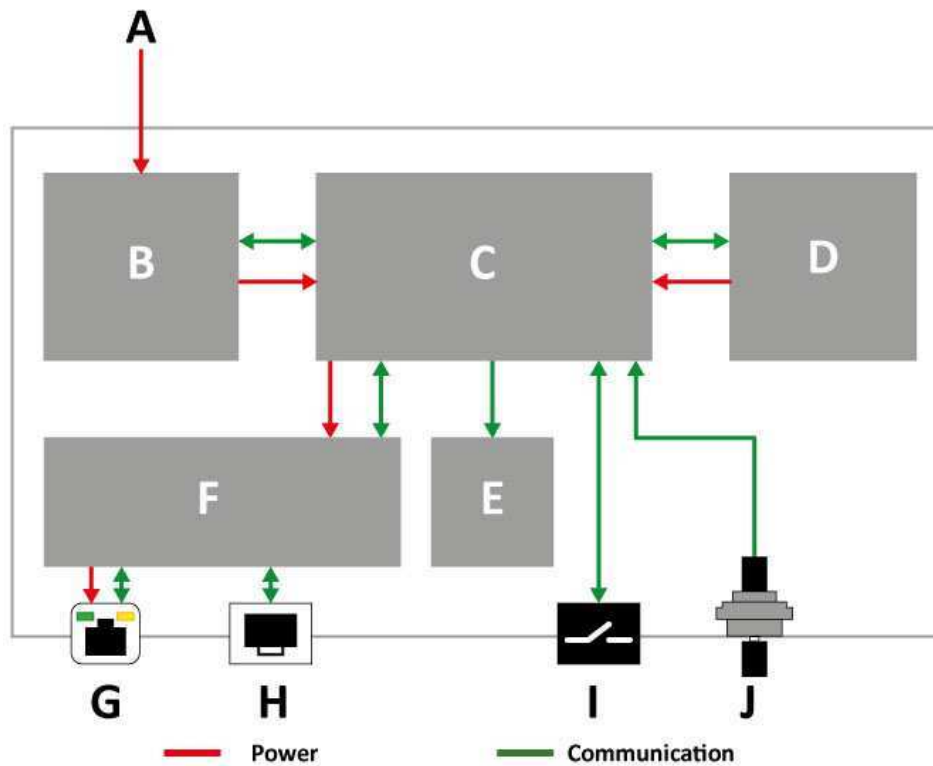

Figure 5.1: Schematic diagram

Element	
A	Mains 230 VAC
B	AC/DC Charger and Controller (Power Supply)
C	System Controller (Functioning and Communication)
D	LiFePO ₄ Battery
E	LED (Status and PoE-Load)
F	Switch (HiPoE/SFP)
G	Ethernet Ports (PoE/PoE+/HiPoE)
H	SFP Ports
I	Input/Alarms report
J	Reboot/Reset button

Table 5.1: Elements of the schematic diagram

5.4 Product view

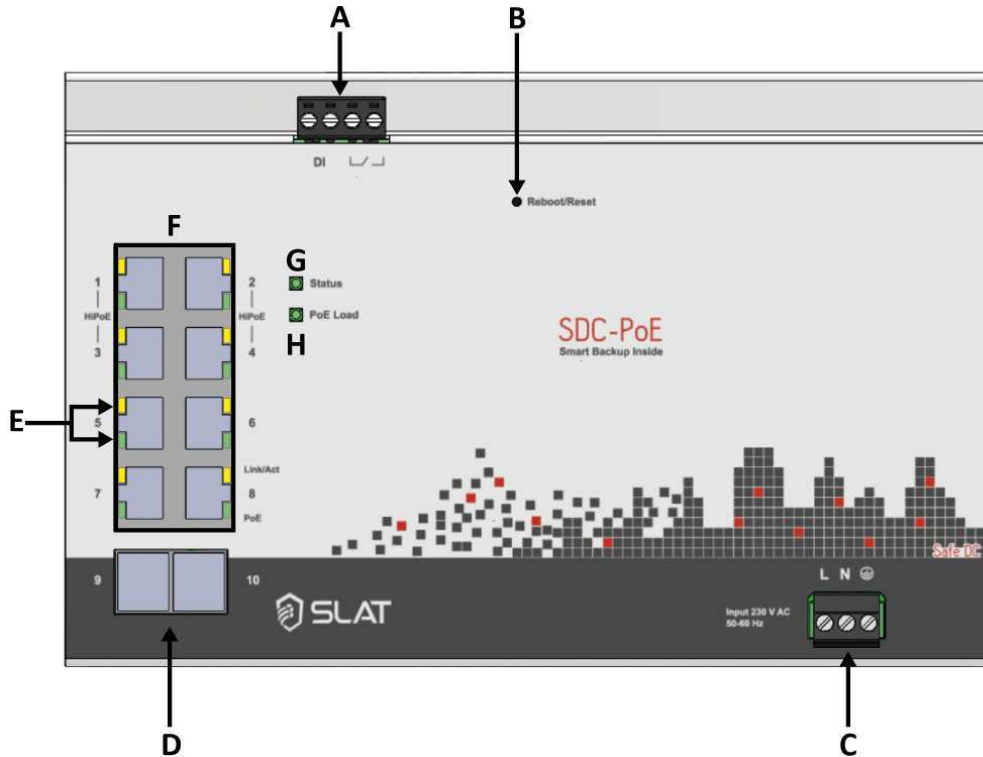

Figure 5.2: Front view

	Name	Use
A	Input fault	Digital Input (DI)
	Alarm reports	Dry contact (NC)
B	Reboot/Reset button	The Reboot/Reset button can be used to: - reboot (Reboot device). - reset parameters (factory reset).
C	Mains input	Mains input via a plug-in terminal.
D	SFP port	Communication speed: 100/1000 Mbps The communication uses a SFP module connection and the SNMP, HTTPS or BACnet IP protocol to retrieve detailed product information (see chapter 9.3).
E	LED "PoE" of each port	The lights indicate the PoE status of and the delivered power to each port (see chapter 9.1).
F	Ethernet port (PoE / PoE+ / HiPoE)	Communication speed: 10/100/1000 Mbps The communication uses an Ethernet connection and the SNMP, HTTPS or BACnet IP protocol to retrieve detailed product information (see chapter 9.3). These ports supply power via PoE/PoE+/HiPoE to the connected equipment (application).
G	LED "Status"	The light indicates the product status (see chapter 9.1).
H	LED "PoE Load"	The light indicates the PoE load level (see chapter 9.1).

Table 5.2: Elements on the product faces

5.5 Scope of delivery

The product is delivered with:

- 1x installation manual

6. Energy storage

6.1 Available storage option

SLAT products are combined with batteries or backup systems. They are used as emergency supplies in the event the mains voltage disappears. The available autonomy then depends on the capacity of the built-in backup.

In the **SDC-PoE8** the backup system is already built-in (Smart Backup Inside). The **SDC-PoE8** is fitted with one backup of minimum guaranteed capacity **72Wh (backup F)**.

6.2 Technology

The technology behind the **SDC-PoE8** backup is Lithium-Iron-Phosphate (LiFePO_4). LiFePO_4 offers the best safety characteristics of any Lithium storage system (see Figure 6.1). This includes better resistance to impacts and to extreme temperatures.

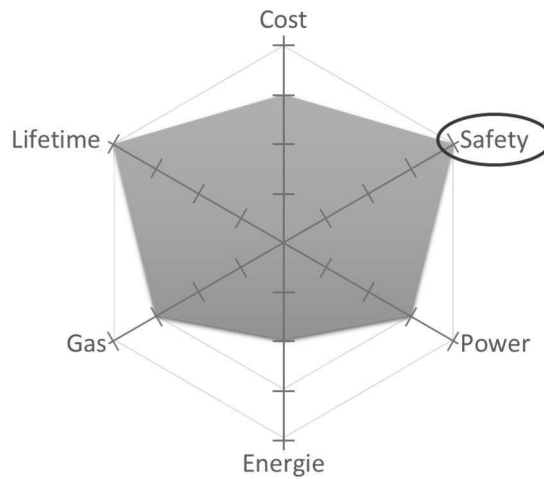

Figure 6.1: LiFePO_4 characteristics

The SDC-PoE8 backups has the following characteristics:

- Lithium-Iron-Phosphate technology (LiFePO_4)
- No risk of thermal runaway
- Storage: 9 months without recharging
- 10 year service life @ 25°C
- Lead-free, cadmium-free, 100% recyclable

6.3 Autonomy curves

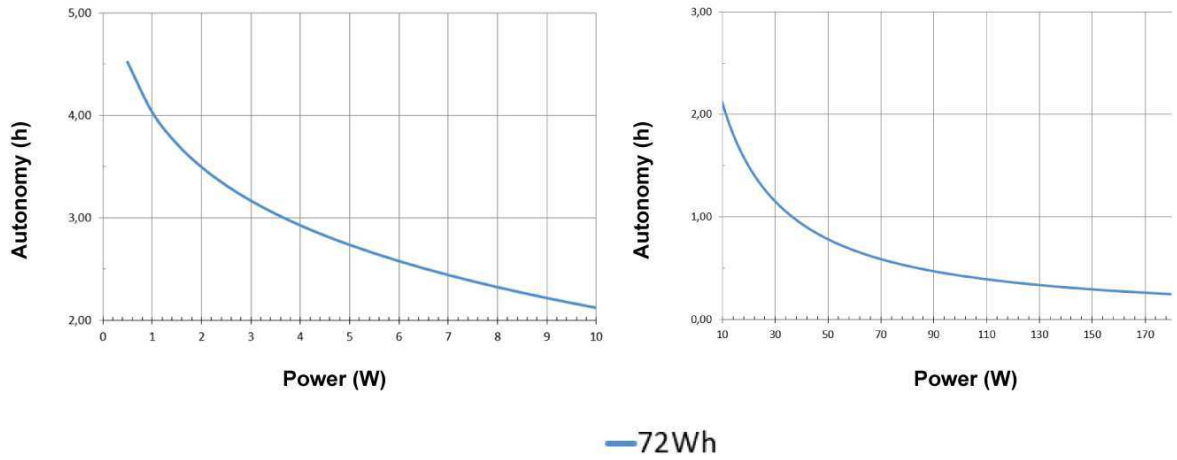

Figure 6.2: Autonomy curves

6.4 Autonomy duration

Operating power	Backup F
	Autonomy expressed in hours and minutes
0 W	4h31
10 W	2h07
20 W	1h29
30 W	1h09
40 W	0h56
50 W	0h47
60 W	0h40
70 W	0h35
80 W	0h31
90 W	0h28
100 W	0h26
110 W	0h23
120 W	0h22
130 W	0h20
140 W	0h19
150 W	0h17
160 W	0h16
170 W	0h15
180 W	0h14

Table 6.1: Autonomy vs Power vs used Backup

7. Installation

The product must be installed according to the EN 69950-1 and EN 62368-1 standards.

The installation of the SDC-PoE8 is done without opening the product.

7.1 Positioning / Installation on support

The SDC PoE8 can be fitted inside a non-ventilated electrical equipment cabinet. Product cooling by natural convection requires a top/bottom clearance of at least 30 mm.



DANGER !

This product must be installed in an IP30 rated cabinet.

The DIN4 box of the SDC-PoE8 is designed to be fixed to a DIN rail:

1. Position the top part of the attachment (on the rear of the product) on the top part of the rail, tilting the product backwards. Make sure the clip is placed behind the rail.
2. Clip the product to the rail and position it vertically.

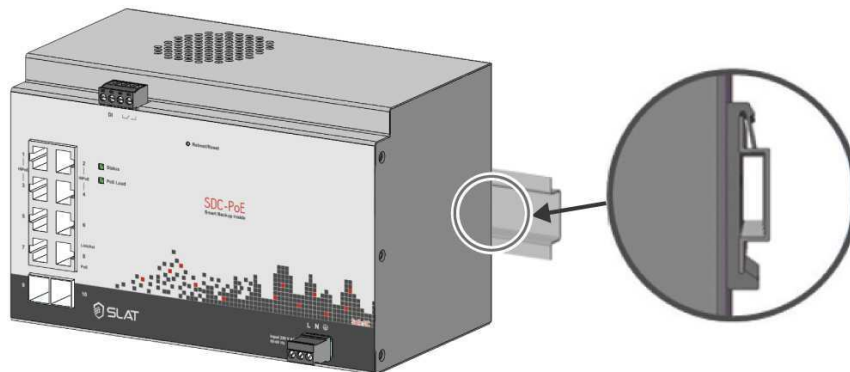

Figure 7.1: Position on the DIN rail once assembled.



CAUTION!

To prevent the product from falling, make sure it is securely attached to the bottom and top of the rail!

7.2 Connection

7.2.1 Connection specifications

Mains	0,3 mm ² ... 2,5 mm ²	
Alarms report	0,3 mm ² ... 2,5 mm ²	
Ethernet Ports (PoE)	Connection 10/100/1000 Mbps	Ethernet cable Cat 5 or more / shielded / straight or twisted cables
SFP Ports	Connection 100/1000 Mbps	SFP module 1000 Mbps
Length to be stripped	7 mm	
Tightening torque	0.5 Nm ... 0.6 Nm	
Connections	Screw terminals, plug-in connectors	
	Ethernet ports (RJ45 connectors)	

Table 7.1: Connection specifications



DANGER !

The wire sectional area must be chosen according to the operating current ($\geq 0,15 \text{ mm}^2/\text{A}$).

7.2.2 Wiring



Figure 7.2: Wiring

Symbols have been placed on the product (above or below the connectors) to facilitate connection (see also Figure 5.2: Front view).

Power supply

The product is connected to the PoE/PoE+/HiPoE applications by the Ethernet ports 1 to 4 and the PoE/PoE+ applications by the Ethernet ports 5 to 8. This connection allows to supply the application, when it is PoE compatible [the output voltage is set in accordance to the PoE standards (IEEE 802.3af/802.3at/802.3bt)].

Communication

The Ethernet and SFP ports allow the communication with an application like a camera or an external controller and the communication with the supervisor. The communication speed for the ports are:

- Ethernet ports 10 / 100 / 1000 Mbps
- SFP ports 100 / 1000 Mbps

The Combo ports have communication speeds corresponding to their type (Ethernet or SFP).



IMPORTANT REMARK!

After installing the product on its support, the wiring must be carried out. In this way, the product is connected to the applications, the supervisor and the mains.

To connect the wires, the cover doesn't need to be opened because the Ethernet and SFP ports as well as the mains connector plug are accessible from the outside.

Wiring methods

The wires for mains input and output are attached to the product using plug-in connectors (the two black parts on Figure 7.2). This makes it possible to carry out the wiring in two different ways:

1. Connect the wires directly to the product
Connect the wires according to the symbols indicated on the product, using a regular screwdriver.
2. Connect the wires to the unplugged connectors and then connect them to the product.
Pull the connectors to remove them from the product. Connect the wires according to the symbols on the product, using a Cross-point screwdriver. Put the connectors back on the product.



CAUTION!

To avoid breaking the connector, comply with the screw tightening torque indicated in Table 7.1. To avoid wiring mistakes, make a careful note of the positioning of the connectors and their respective symbols.

The Ethernet ports are auto MDI-X, such that either straight-through or twisted cables can be used.

Connection



DANGER!

**To connect the wires, the application must be switched off. The upstream circuit-breaker of the application must be open!
The stripped ends of the mains cables must be crimped before being connected to the product terminals!**

The wires are connected according to the following steps:

1. Connect the power supply to the mains
Above the three-point connector (bottom right), the type of wiring is indicated by 3 symbols:
 - L Line wire
 - N Neutral wire
 -  Ground wire



DANGER!

The ground wire must always be connected before connecting the power supply to the mains!

After connecting the ground wire, the neutral and line wires can be connected.

⇒ Once the connections have been made, the upstream circuit-breaker can be closed. To complete the installation, the Status LED must be verified to be green.

2. Connect the applications and the supervisor to the product

For a better identification, each port is numbered (see numbers on the product). Figure 7.2 shows the ports that are accessible from the front:

- 8 Ethernet ports (PoE/PoE+/HiPoE)
- 2 SFP ports

On the SFP ports two types of SFP modules can be used:

- SFP-fiber module (100/1000 Mbps)
- SFP-RJ45 module (100/1000 Mbps)

All ports are auto MDI-X, such that either straight-through or twisted cables can be used.

8. Commissioning

Before starting to commission the switch, check that the LED “Status” on the front is green. This means the product is powered properly and ready to function.

The switch parameters can be configured via the HTTPS website. It also makes it possible to configure the energy saving mode (ECO) and the stealth mode.

Using the onboard website, the system parameters can be defined, the switch and all its ports managed and controlled as well as the network conditions monitored. The administrator can set up the managed switch by selecting the functions listed in the main menu. To be able to communicate with the product, the port, to which the supervisor is connected to, has to be part of the **VLAN 1**.

In order to manage and to communicate with the product, it must be configured according to the following chapters. The computer’s network configuration, to which the product will be connected to, has to be compatible with the product’s network parameters.

8.1 Communication protocols

The product supports the following communication protocols.

Application layer protocols

- HTTPS
- BACnet IP
- SNMP v1, v2c + v3
- DHCP

Network layer protocols

- IPv4
- ICMP

8.2 Assigning an IP address

The DHCP (dynamic IP address allocation) automatically assigns an IP address to a product in order to communicate with it. This feature is enabled by default in the factory configuration. Two different operating modes exist according to the availability or lack of a DHCP server on the network:

A. DHCP server available

If a DHCP server is available, it automatically allocates an IP address to the product. If several products are connected to the network, it assigns a different IP address to each one.

To determine the new address, browse the network.

B. DHCP server not available

If no DHCP server is available on the network, the product uses the IP settings below. When the switch is first connected to the network, it remains in DHCP for 1 minute before switching to the predefined IP address.

- **IP address** **192.168.1.1**
- **Network mask** **255.255.255.0**
- **No gateway**

In this case, if several products need to be connected to a single network, they must be isolated and the IP address of each product must be modified using their HTTPS, to avoid any address conflicts web interface. Indeed, they possess the same IP parameters before being connected to the network. The same procedure applies if the same IP address exists several times on a given network. See the Advanced user’s manual for instructions on changing the IP address.

8.3 Login page – Logging onto the product

Using the allocated or predefined IP address, it is possible to log onto the product using a web browser over HTTPS.

When connecting to the product for the first time with an IP address, the user will have a warning about the website's security certificate. Ignore this warning and proceed to access the website. Each time the product's IP address changes, the user will redo the same operation.



IMPORTANT REMARK!

The default login and password are:

Login: admin

There is no password. Click directly on "OK".

For the security of your installation, it is imperative to set a password



Figure 8.1: Login page

8.4 Web-based user interface – Description

After entering the login and the password in the login page and once connection with the product has been established, the "System Information" page of the section "System State" is displayed.

The user interface, as shown in Figure 8.2, is divided in three areas: headline, main menu and main screen.

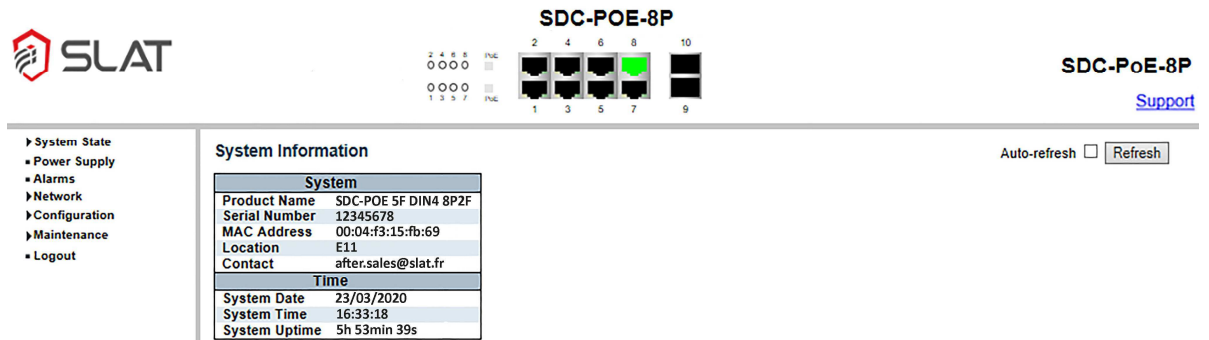





Figure 8.2: User interface

8.4.1 Headline

The headline is the area on top of each page. It is the same for each page of the menu. In the center, it contains the product's name defined in the "Settings Configuration" page as well as the port indicators and the PoE LEDs. The featured port numbers in the headline correspond to the numbers on the switch. The colors of the port indicators inform about the link working status.

-  link 10/100 Mbps (yellow)
-  link 1000 Mbps (green)
-  no link (black)

The PoE LED symbols to the left of the 2x4 RJ45 connector block symbol indicate the status of the PoE power supply.

- Blue – powered over PoE
- Red – fault on the PoE
- White – no powered PoE

The user can send an email to SLAT's after-sales service thanks to the "Support" link, located on the right side of the headline.

8.4.2 Main menu

The main menu is situated on the left side of the interface. It gives an overview of the different sections and allows access to all the pages of this site. The pages are organized in the following sections:

- System State
- Power Supply
- Alarms
- Network
- Configuration
- Maintenance
- Logout

8.4.3 Main screen

The main screen will occupy most of the screen space and will contain the relevant information for the section selected.

Depending on the page, the user has access to either information or configurable parameters.

8.5 Configuration and operation of the switch

The switch's functions can be set up and the operating of the switch can be supervised via the embedded website.

Information regarding the configuration of the switch functionalities and the operation of the switch can be found in the "advanced user's manual". It can be downloaded in MySLAT at www.slat.com.

8.6 Reboot device

The reboot can be performed on the onboard website or on the product

Via the onboard website

To reboot the product (Reboot device) select "Reboot device" in the maintenance section of the maintenance page. Click on "yes" in "Reboot device" and wait for the end of the countdown (120 seconds). Once rebooted, the return to the page "system information" is automatic.



Figure 8.3: Reboot on the onboard website

On the product

The "PoE Load" and "Status" LEDs turn off for a few seconds and then light green until restart. The total duration of the restart is 2 minutes.

8.7 Factory configuration reset

The reset can be performed on the onboard website or on the product.

Via the onboard website

To reset the product (Factory reset) select "Factory reset" in the maintenance section of the maintenance page. Click on "yes" in "Factory reset" and wait for the end of the countdown (120 seconds). Once the reset is complete, the return to the "login" page is automatic. You have to log in again as described in chapter 8.3 on page 18.

The "PoE Load" and "Status" LEDs will go out for a few seconds and then light green until restart. The total duration of the restart is 2 minutes.



Figure 8.4: Reset on the onboard website

On the product

The reset consists of configuring the product with factory parameters. This reset is done by pressing the reboot/Reset in the front. When the led « status » are blinking green/red release the button, the reset is complete.

8.8 Product switch-off

To stop and switch-off the product, It's necessary to:

- Disconnect the network cables.
- Disconnect the mains.
- Wait one (1) minute until the product has shut down.

9. Operation

During use, it is possible to interact with the product. There are two types of communication: local report and/or remote report.

9.1 Local report on product

Status LED

The Figure 5.2 in chapter 5.4 indicates the position of the “Status”, “PoE Load”, “PoE” and “Link/Act” LED on the product.

Status LED

The product communicates its status via a Status LED on the front. The LED indicates the different statuses of the product by its color and state. The table explains the meanings of each state.

Color and state		Mode
Green	steady	Normal mode without fault
	slow flashing	Eco Mode or Stealth Mode
Orange	slow flashing	Backup mode Mains outside specified power supply range
	fast flashing	Installation fault End of backup or stop imminent
Red	steady	Change product
		If product out of order (charger fault)
		Fan rotor locked
		Temperature sensor failure or disconnected
		Communication Failure with the Power Supply
		Communication Failure with the Switch
		Backup alarm

Table 9.1: Status LED state

“PoE Load” LED

The product communicates the PoE load level via the PoE Load LED on the front. The LED indicates the different power levels of the PoE load by its color. The table explains the meanings of each color.

Color		Mode
Green	steady	Power \leq 80%
Orange	steady	80% < Power \leq 100%
Red	steady	100% < Power or boost DC/DC failure

Table 9.2: PoE Load LED state

PoE LED (RJ45)

The product indicates the state of the PoE/PoE+/HiPoE supply of the Ports 1 to 4 and PoE/PoE+ supply of the Ports 4 to 8 via the LEDs at the bottom of each one of these ports (see Figure 5.2 page 9). When the application, which is connected to one of the ports, is supplied via PoE, the corresponding LED shines green.

Link LED (RJ45)

The product indicates the Ethernet connection status of an application to the Ports 1 to 4 via the LEDs on the top of each one of these ports (see Figure 5.2 page 9). When a connection between an application and a port is established, the port's Link LED shines.

Color	Mode
Yellow	steady
	flashing

Table 9.3: Link LED state

9.2 Input fault and alarms report by dry contact

9.2.1 Input fault by dry contact (Digital Input)

An input is available for customer applications and allows the transmission of information by dry contact (e.g. door opening control, lightning arrester, fire detection...).

9.2.2 Alarms report by dry contact NC

Alarms can be reported by dry contact (positive safety contact: coils activated without default). You can choose the type of alarm report on the embedded website in the "Alarms" section.

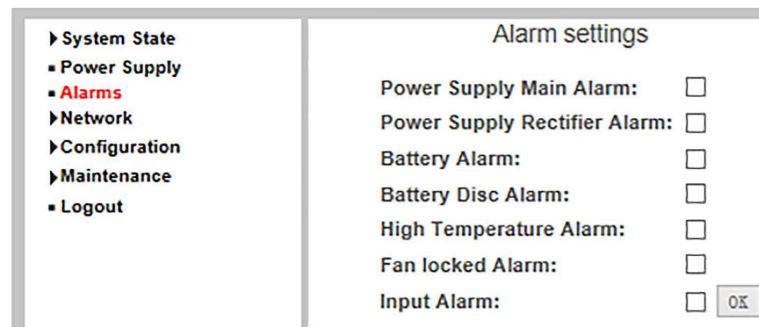

9.3 Remote report – Communication

When using the product, it is possible to communicate with it from a distance using the incorporated communication system.

The product communicates its information on the Ethernet connection via the HTTPS, SNMP and BACnet IP application protocols. The protocols can be configured via the page "SNMP – BACnet" of the embedded website. The configuration procedure is described in the Advanced user's manual.

The information and explanations on how to configure the product are described in chapter 8 and the Advanced user's manual.

The following chapters describe the information available via the different protocols.

9.3.1 Accessible data

The following data is available via SNMP and BACnet IP.

Bit	Name	Description
30 - 31	- Reserved -	-
29	Input status dry contact	If the bit is at 1, input fault is present
28	DC Relay output	If the bit is set to 1, the relay contact is open.
27	Fan rotor locked	If the bit is at 1, fan rotor is locked
26	Ethernet Failure	In read mode, if the bit is set to 1, then one or more Ethernet connections have been lost. The fault remains active even if the links are re-connected. To acknowledge the fault, set bit to 1, which then switches to 0 in read mode.
25	Halt Stealth	Set bit to 1 to stop Stealth Mode. The bit remains set to 0 in read mode.
24	Start Stealth / Stealth State	In read mode, if the bit is set to 1, then Stealth Mode is enabled. Set bit to 1 to start Stealth Mode.
23	Reset factory	The factory reset is in progress or has been requested.
22	- Reserved -	-
21	Battery	If the bit is at 1, battery is present
20	Battery Communication Failure	If the bit is 1, No communication between the battery and the product
19	Communication Failure with the Power Supply	Communication failure with the power supply if the bit is 1. The values of the read data are not significant.
18	Communication Failure with the Switch	Communication failure with the switch if the bit is 1. The values of the read data are not significant.
17	General Communication Failure	General communication failure if the bit is 1. The values of the read data are not significant.
16	DC/DC converter Failure	DC/DC converter failure if the bit is 1. The values of the read data are not significant.
14 - 15	- Reserved -	-
13	End of Autonomy	End of autonomy pre-alarm when the bit is set to 1.
12	Battery Failure	If the bit is set to 1, the product must be replaced: the battery is defective or has been removed.
11	Rectifier Failure	If the bit is set to 1, the product must be replaced: the charging system is faulty and the battery may not be charged.
10	Mains Failure	If the bit is set to 1, mains power is absent.
9	Output Overload	If the bit is set to 1, the total PoE budget is exceeded.
8	- Reserved -	-
7	High Temperature	If the bit is set to 1, the temperature in the product is too high.
6	Battery Disconnection	If the bit is set to 1, the battery is disconnected.
5	Stealth Mode or Eco Mode	If the bit is set to 1, then Stealth Mode or Eco mode is enabled.
4	- Reserved -	-
3	Temperature Sensor Failure	Temperature sensor failure if the bit is 1. The values of the read data are not significant.
0 - 2	- Reserved -	-

Table 9.4: Detail of the "System state" variable

Bit	Name	Description	
26 - 31	- Reserved -	-	
24 - 25	Ethernet State	Ethernet port status:	
		Value	Status
		00	No link
		01	10 Mbps link
		10	100 Mbps link
20 - 23	PoE Class	PoE-class:	
		Value	Class
		0000	0
		0001	1
		0010	2
		0011	3
		0100	4
		0101	5
		0110	6
		0111	7
18 - 19	PoE Management	PoE control (read/write):	
		Value	Status
		00 (write : no effect)	- Reserved -
		01	Stop PoE
		10	Start PoE
16 - 17	PoE State	PoE status:	
		Value	Status
		00	PoE stopped
		01	PoE on hold
		10	PoE defective
0 - 15	PoE Power	PoE output power expressed in tenths of a Watt	
		Value	Status
		00	PoE stopped
		01	PoE on hold
		10	PoE defective
11	PoE active		

Table 9.5: Detail of the "Ethernet port X state" variable

9.3.2 HTTPS Protocol

The HTTPS website provides product management and data processing-related information.

Chapter 8 and the Advanced user's manual describe the use of the HTTPS website and the various data available.

To log onto the embedded website, use the selected login and password. The Advanced user's manual explains how to change the password.

9.3.3 SNMP Protocol

2 MIBs are available over SNMP (v1, v2c, v3):

- The **MIB-2**, defined by the RFC1213 standard.
- The **MIB SLAT-SDC** is proprietary and specific to SLAT. It is common to the entire Safe DC range.
The MIB SLAT-SDC is downloadable only from the embedded website (HTTPS) on the "Network/Network Administration/SNMP - BACnet" page.



IMPORTANT REMARK!

For the SNMP v1 and v2c the Write Community is "private".
 For the SNMP v3 the user and the password have to be configured.

The following variables are available via SNMP:

<u>MIB-2</u>		
Variable	SNMP Name	Description
Model	sysDesc	SDC reference and version.
System name	sysName	SDC system name (available in write mode, up to 16 characters)
Location	sysLocation	SDC location (available in write mode, up to 32 characters)

Table 9.6: MIB-2 variables

MIB SLAT-SDC		
Variable	SNMP Name	Description
Model	model	SDC reference and version.
Capacity	capacity	Battery capacity: energy expressed in Watt-hours.
Serial number	serialNumber	SDC serial number.
System state	systemState	32-bit variable presenting the state of the SDC system. Each time a change is made, this variable is sent in the form of an SNMP trap (for details of the variable, see Table 9.4) *.
Gauge	energyGauge	Gauge in percent, corresponding to the amount of energy available in the battery. A value of 100 corresponds to a fully charged battery.
Output voltage	outputVoltage	Output voltage: the value is expressed in tenths of a Volt.
Output current:	outputCurrent	Output current: the value is expressed in tenths of an Ampere.
Output power	outputPower	Instantaneous power supplied by the SDC: the value is expressed in Watts.
Mains power	mainsPower	Instantaneous mains power input: the value is expressed in Watts.
Temperature	temperature	SDC internal temperature: the value is expressed in °C.
Total discharged energy	totalDischargedEnergy	Amount of energy provided by the SDC battery since initial commissioning: the value is expressed in tenths of a Watt-hour.
Mains cut total number	mainsCutTotalNumber	Total number of power cuts since initial commissioning.
Output voltage adjustment	voutAdjust	Not applicable for SDC-PoE products.
Stealth Mode threshold	stealthModeThreshold	Minimum battery charge level in percent for Stealth Mode. Accepted values: 25, 50, 75 or 100. The value 100 disables the Stealth Mode.
Eco Mode threshold	ecoModeThreshold	Minimum battery charge level in percent for Eco Mode. Accepted values: 50, 60, 70, 80 or 100. The value 100 disables Eco Mode.
Ethernet port X state	ethernetPortX-State	32-bit variable presenting the status of each Ethernet port X representing the port number (for details of this variable, see Table 9.5).

Table 9.7: MIB SLAT-SDC variables

* To use SNMP traps, the IP addresses of the SNMP servers to which the traps should be sent must be entered into the HTTPS website (see the Advanced user's manual).

9.3.4 BACnet IP Protocol

The following objects are accessible via BACnet IP:

Property	Remark / Value	RW
Object_Identifier	Product instance, by default: 421000	RW-E
Object_Name	SDC system name (max. 16 characters). By default: ""	RW-E
Object_Type	8 : Object Device	R
System_Status	0 : Operational or 4 : No Operational if not ready	R
Vendor_Name	"SLAT"	R
Vendor_Identifier	954	R
Model_Name	Product type or -	R
Location	Product location (max. 32 characters). By default: ""	RW-E
Firmware_Revision	Communication firmware version	R
Application_Software_Version	""	R
Protocol_Version	1	R
Protocol_Revision	12	R
Protocol_Services_Supported	Read Property, Read Prop Multiple, Write Property, Device Communication Control, Reinitialize Device, who-is.	R
Protocol_Object_Types_Supported	DEVICE, ANALOG_VALUE, POSITIVE_INTEGER_VALUE	R
Object_List [26]	device, analog-value 0 ...10, positive_integer_value 0...12	R
Max_APDU_Length_Accepted	1476	R
Segmentation_Supported	3 : None	R
APDU_Timeout	3000	R
Number_Of_APDU_Retries	3	R
Device_Address_Binding	-	R
Database_Revision	0	R
Serial_Number	Serial number	R
R: Read Property, W: Write Property, -E: Storage in EEPROM / Flash		

Table 9.8: BACnet IP variables

Analog Value Object 0		
Property	Remark / Value	RW
Object_Identifier	OBJECT_ANALOG_VALUE:0	R
Object_Name	"Vout"	R
Object_Type	2 : Object Analog Value	R
Description	"Output voltage"	R
Present_Value	Output Voltage	R
Status_Flags	In Alarm: 0	R
	Fault: 0	
	Overridden: 0	
	Out Of Service: 0	
Event_State	0 : Normal	R
Out_Of_Service	False	R
Units	5 : Volts	R
R: Read Property, W: Write Property, -E: Storage in EEPROM / Flash		

Table 9.9: Analog Value Object 0

Analog Value Object 1		
Property	Remark / Value	RW
Object_Identifier	OBJECT_ANALOG_VALUE:1	R
Object_Name	"Iout"	R
Object_Type	2 : Object Analog Value	R
Description	"Output current"	R
Present_Value	Output current	R
Status_Flags	In Alarm: 0	R
	Fault: 0	
	Overridden: 0	
	Out Of Service: 0	
Event_State	0 : Normal	R
Out_Of_Service	False	R
Units	3 : Amperes	R
R: Read Property, W: Write Property, -E: Storage in EEPROM / Flash		

Table 9.10: Analog Value Object 1

Analog Value Object 2		
Property	Remark / Value	RW
Object_Identifier	OBJECT_ANALOG_VALUE:2	R
Object_Name	"Pout"	R
Object_Type	2 : Object Analog Value	R
Description	"Output power"	R
Present_Value	Output power	R
Status_Flags	In Alarm: 0	R
	Fault: 0	
	Overridden: 0	
	Out Of Service: 0	
Event_State	0 : Normal	R
Out_Of_Service	False	R
Units	47 : Watts	R
R: Read Property, W: Write Property, -E: Storage in EEPROM / Flash		

Table 9.11: Analog Value Object 2

Analog Value Object 3		
Property	Remark / Value	RW
Object_Identifier	OBJECT_ANALOG_VALUE:3	R
Object_Name	"Pin"	R
Object_Type	2 : Object Analog Value	R
Description	"Mains Input power"	R
Present_Value	Mains power	R
Status_Flags	In Alarm: 0	R
	Fault: 0	
	Overridden: 0	
	Out Of Service: 0	
Event_State	0 : Normal	R
Out_Of_Service	False	R
Units	47 : Watts	R
R: Read Property, W: Write Property, -E: Storage in EEPROM / Flash		

Table 9.12: Analog Value Object 3

Analog Value Object 4		
Property	Remark / Value	RW
Object_Identifier	OBJECT_ANALOG_VALUE:4	R
Object_Name	"Temperature"	R
Object_Type	2 : Object Analog Value	R
Description	"Internal temperature"	R
Present_Value	Internal temperature	R
Status_Flags	In Alarm: 0	R
	Fault: 0	
	Overridden: 0	
	Out Of Service: 0	
Event_State	0 : Normal	R
Out_Of_Service	False	R
Units	62 : Degrees Celsius	R
R: Read Property, W: Write Property, -E: Storage in EEPROM / Flash		

Table 9.13: Analog Value Object 4

Analog Value Object 5		
Property	Remark / Value	RW
Object_Identifier	OBJECT_ANALOG_VALUE:5	R
Object_Name	"BatteryGauge"	R
Object_Type	2 : Object Analog Value	R
Description	"Remaining autonomy"	R
Present_Value	Battery gauge	R
Status_Flags	In Alarm: 0	R
	Fault: 0	
	Overridden: 0	
	Out Of Service: 0	
Event_State	0 : Normal	R
Out_Of_Service	False	R
Units	98 : Percent	R
R: Read Property, W: Write Property, -E: Storage in EEPROM / Flash		

Table 9.14: Analog Value Object 5

Analog Value Object 6		
Property	Remark / Value	RW
Object_Identifier	OBJECT_ANALOG_VALUE:6	R
Object_Name	"BatteryCapacity"	R
Object_Type	2 : Object Analog Value	R
Description	"Installed battery capacity"	R
Present_Value	Battery capacity	R
Status_Flags	In Alarm: 0	R
	Fault: 0	
	Overridden: 0	
	Out Of Service: 0	
Event_State	0 : Normal	R
Out_Of_Service	False	R
Units	18 : Watt Hours	R
R: Read Property, W: Write Property, -E: Storage in EEPROM / Flash		

Table 9.15: Analog Value Object 6

Analog Value Object 7		
Property	Remark / Value	RW
Object_Identifier	OBJECT_ANALOG_VALUE:7	R
Object_Name	"StealthModeThreshold"	R
Object_Type	2 : Object Analog Value	R
Description	"Minimum battery gauge level for Stealth Mode (25%, 50% or 75% - 100% disables Stealth Mode)"	R
Present_Value	Stealth Mode threshold	R
Status_Flags	In Alarm: 0	R
	Fault: 0	
	Overridden: 0	
	Out Of Service: 0	
Event_State	0 : Normal	R
Out_Of_Service	False	R
Units	98 : Percent	R
R: Read Property, W: Write Property, -E: Storage in EEPROM / Flash		

Table 9.16: Analog Value Object 7

Analog Value Object 8		
Property	Remark / Value	RW
Object_Identifier	OBJECT_ANALOG_VALUE:8	R
Object_Name	"EcoModeThreshold"	R
Object_Type	2 : Object Analog Value	R
Description	"Minimum battery gauge level for Eco Mode (50%, 60%, 70% or 80% - 100% disables Eco Mode)"	R
Present_Value	Eco Mode threshold	R
Status_Flags	In Alarm: 0	R
	Fault: 0	
	Overridden: 0	
	Out Of Service: 0	
Event_State	0 : Normal	R
Out_Of_Service	False	R
Units	98 : Percent	R
R: Read Property, W: Write Property, -E: Storage in EEPROM / Flash		

Table 9.17: Analog Value Object 8

Analog Value Object 9		
Property	Remark / Value	RW
Object_Identifier	OBJECT_ANALOG_VALUE:9	R
Object_Name	"TotalDischargedEnergy"	R
Object_Type	2 : Object Analog Value	R
Description	"TotalDischargedEnergy "	R
Present_Value	Total discharged energy	R
Status_Flags	In Alarm: 0	R
	Fault: 0	
	Overridden: 0	
	Out Of Service: 0	
Event_State	0 : Normal	R
Out_Of_Service	False	R
Units	18 : Watt Hours	R
R: Read Property, W: Write Property, -E: Storage in EEPROM / Flash		

Table 9.18: Analog Value Object 9

Analog Value Object 10		
Property	Remark / Value	RW
Object_Identifier	OBJECT_ANALOG_VALUE:10	R
Object_Name	"MainsCut"	R
Object_Type	ANALOG_VALUE (2)	R
Description	"Mains cut total number"	R
Present_Value	Total number of power cuts	R
Status_Flags	In Alarm: 0	R
	Fault: 0	
	Overridden: 0	
	Out Of Service: 0	
Event_State	0 : Normal	R
Out_Of_Service	False	R
Units	95 : No Units	R
R: Read Property, W: Write Property, -E: Storage in EEPROM / Flash		

Table 9.19: Analog Value Object 10

Positive Integer Value Object 0		
Property	Remark / Value	RW
Object_Identifier	OBJECT_POSITIVE_INTEGER_VALUE:0	R
Object_Name	"SystemState"	R
Object_Type	48 : Object Positive Integer Value	R
Description	"System state register"	R
Present_Value	System state [32 bit]*	R
Status_Flags	In Alarm: 0	R
	Fault: 0	
	Overridden: 0	
	Out Of Service: 0	
Units	95 : No Units	R
R: Read Property, W: Write Property, -E: Storage in EEPROM / Flash		

Table 9.20: Positive Integer Value Object 0

*To consult the detail of the "Present Value – System state" see Table 9.4.

Positive Integer Value Object 1		
Property	Remark / Value	RW
Object_Identifier	OBJECT_POSITIVE_INTEGER_VALUE:1	R
Object_Name	"StealthMode"	R
Object_Type	48 : Object Positive Integer Value	R
Description	"Stealth mode operating"	R
Present_Value	Stealth Mode disabled if null, else enabled	RW
Status_Flags	In Alarm: 0	R
	Fault: 0	
	Overridden: 0	
	Out Of Service: 0	
Units	95 : No Units	R
R: Read Property, W: Write Property, -E: Storage in EEPROM / Flash		

Table 9.21: Positive Integer Value Object 1

Positive Integer Value Object 2		
Property	Remark / Value	RW
Object_Identifier	OBJECT_POSITIVE_INTEGER_VALUE:2	R
Object_Name	"SerialNumber"	R
Object_Type	48 : Object Positive Integer Value	R
Description	"Serial number"	R
Present_Value	Serial number	R
Status_Flags	In Alarm: 0	R
	Fault: 0	
	Overridden: 0	
	Out Of Service: 0	
Units	95 : No Units	R
R: Read Property, W: Write Property, -E: Storage in EEPROM / Flash		

Table 9.22: Positive Integer Value Object 2

Positive Integer Value Object 3		
Property	Remark / Value	RW
Object_Identifier	OBJECT_POSITIVE_INTEGER_VALUE:3	R
Object_Name	"Ethernet1"	R
Object_Type	48 : Object Positive Integer Value	R
Description	"1st Ethernet port state"	R
Present_Value	Port 1 status *	R
Status_Flags	In Alarm: 0	R
	Fault: 0	
	Overridden: 0	
	Out Of Service: 0	
Units	95 : No Units	R
R: Read Property, W: Write Property, -E: Storage in EEPROM / Flash		

Table 9.23: Positive Integer Value Object 3

*To consult the detail of the "Present Value - Port 1 status" see Table 9.5.

Table 9.23 is the object for the Ethernet port 1. For the ports 2 to 8 use the same table with the following formulas (X = port number):

- Object identifier "Positive integer Value" Object 2 + X
- Object Name: "EthernetX"
- Description: "Xth Ethernet port state"
- Present value: Port X status

10. Maintenance and troubleshooting

The product has been designed to function for a long period of time without requiring maintenance. To ensure the best level of service, it is essential to install it in a dry dust-free location.

For a proper functioning of the product, it is necessary to ensure that the ventilation grilles are dust-free.

Troubleshooting

During installation, commissioning or use, unexpected situations may arise. In the event of a problem, the table below can be consulted. It contains a list of possible problems with their corresponding causes and solutions.

Problem	Fault via communication	Cause	Solution
The product does not start. The <i>Status and PoE LED</i> remains off.	No communication	The mains voltage is not connected or is not present.	Check if the mains voltage is connected properly.
		The mains voltage fuse is faulty or absent.	Replace the product.
The <i>Status LED</i> is red. The output voltage is OK.	Backup fault	Backup malfunction; the backup is disconnected or has failed.	Replace the product.
	Fan rotor failure	Fan rotor locked	Replace the product.
	Temperature sensor failure	Temperature sensor failure out of order or disconnected	Replace the product.
	Communication Failure	With power supply out of order	Replace the product.
		With the switch out of order	Replace the product.
Charger fault	Charger malfunction.	The charger has failed. Replace the product.	
The <i>Status LED</i> is red + slow flashing	Internal communication fault	Wiring problem controller/power supply	Replace the product.
The <i>PoE LED</i> is red	Output overload	There is a slight overload on the output.	Lower the output load until the current is less than the maximum output value (see Table 11.3).
No connection: The <i>Link LED</i> of the Port 1 to 22 are not illuminated.	No communication	Bad Ethernet connection.	Verify the connection and use an appropriate Ethernet cable (see Table 7.1).
The <i>Status LED</i> and one <i>Link/Act LED</i> are illuminated but there is no communication.	No communication	Configuration problem.	Check that the configuration of the SDC and the computer are compatible (see chapter 8).
One LED <i>PoE (RJ45)</i> is green+ fast flashing	Short-circuit	Short-circuit to the corresponding <i>PoE</i> port	Delete the short-circuit
The product's IP address is lost.	No communication	-	Perform a factory configuration reset (see chapter 8.7).
The administrator's password has been lost.	No communication	-	Perform a factory configuration reset (see chapter 8.7).

Table 10.1: Problems, causes and solutions

For additional technical assistance, contact the SLAT hotline +33 4 78 66 63 70.

For an RMA request (authorization to return goods), refer to chapter 12.2 .

No equipment may be returned without prior issuance of an RMA number.

11. Technical data

11.1 Electrical characteristics

11.1.1 Electrical characteristics of the power supply

Mains input	
AC network voltage	230 VAC (195,5-264,5 VAC)
Frequency	50-60 Hz (45-65 Hz)
Class	1
Inrush current	Limited by NTC
Neutral system	TT, TN, IT
Primary short-circuit protection	Slow-blow fuse on the phase
Characteristics of built-in fuse	3.15 A (slow-blow, internal)
Shock wave protection	Differential mode by varistor, filter and fuse
Primary current @ 230 V	2.10 A
Primary current @ 265 V	1.85 A
Primary current @ 195 V	1.70 A
Residual consumption in Eco and Stealth Mode	< 1 W
Circuit breaker to be provided upstream	Curve D – 2 A

Table 11.1: Mains input electrical characteristics

Current behavior - Inrush current at start-up

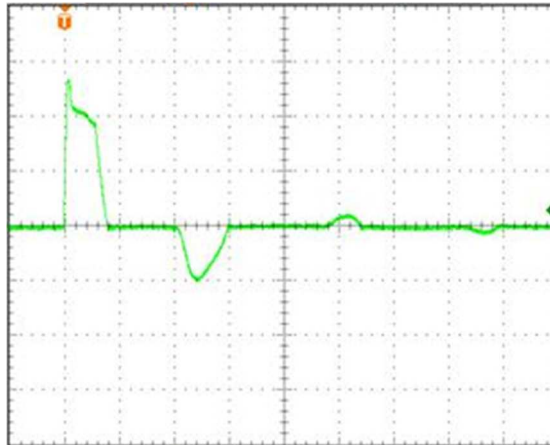

Figure 11.1: Oscillogram - inrush current

Test conditions	
Input voltage	265 VAC
Output current and voltage	55 VDC; no load
Ambient temperature	+20°C
Description of the diagram	
Input current	10 A / DIV
Time scale	4 ms / DIV

Table 11.2: Description of the oscillogram - inrush current

11.1.2 Electrical output characteristics

Output	
Standards	IEEE 802.3af, IEEE 802.3at IEEE 802.3bt
Rated voltage U_n	55 V
Voltage precision	< 5 %
PoE budget	15 à 90 W/port, budget total PoE 180 W
Courant limitation	from I_n to $I_n+15\%$ for output voltage > 50% of U_n
HF ripple peak-peak (20 MHz-50 Ω)	< 4% of U_n
Switching frequency	65 kHz+/-10%
Effective LF ripple	< 0.2% of U_n
Static and dynamic regulation characteristics	< 5% of U_n for cumulative variations of the mains and the load (from 10 to 90%)
Protection	fuse
η (Smart backup) @ 25% of use load	74%
η (Smart backup) @ 75% of use load	83%
η (Smart backup) @ 100% of use load	88%
Protection against output short-circuit	by power supply cut with cyclical restart
Protection against surges in user output	deregulation or connection error, by cut-off with cyclical restart if output voltage > $U_n + 10\%$
Short circuit if	$U_{output} < 30 V$ or $I > 1.2 A$

Table 11.3: Electrical output characteristics

11.1.3 Functional characteristics

The switch SDC-PoE24 handles the data flow from the connected devices. It improves the availability of the critical applications while protecting the sensitive information.

Up to 22 PoE Ethernet ports permanently supply (after negotiation) a constant voltage (55 VDC) to the equipment which has to be powered. In the event of a current break, the built-in backup maintains the electrical power supply of the equipment connected to the product for the duration defined when the SDC-PoE24 was chosen.

An Ethernet connection allows to retrieve the information including the analogue values remotely (voltages and load current, backup, autonomy, internal electronic temperature).

By default, the DHCP is active. The HTTPS webserver makes it possible amongst others to configure the switch functionalities and communication parameters as well as to choose the functioning mode.

There are also several LEDs in the front informing about the functioning of the switch.

11.2 Mechanical characteristics

Mechanical specifications	
Envelope	Aluminium
Protection rating	IP30
Cabinet dimensions	W 215 x H 138 x D 122 mm
Overall dimensions	W 215 x H 138 x D 148 mm
Weight	2,2 kg
Installation	Cabinet mounted on a Din rail

Table 11.4: Mechanical specifications

11.3 Environmental specifications

Environmental specifications		
Storage temperature		-25 ... +60°C
Operating temperature	at 100% load	-10 ... +45°C
	at 75% load	-10 ... +50°C
Relative humidity (non-condensing)	in storage	10 ... 90%
	operating	20 ... 85%
Cooling	The cooling is carried out transversally.	
Altitude	Above 2,000 m, the temperature decreases by 5% every 1,000 m.	

Table 11.5: Environmental specifications

11.4 Standards

The product is designed to meet with IEEE standards as well as LV and EMC directives (immunity and emission). It complies with the following standards.

11.4.1 Safety standards

The standards for the safety – low voltage directives (LVD) are:

Section	Standard number	Title/Content
LVD Safety	EN 60950-1 (2006) + A11 (2009) + A1 (2010) + A12 (2011) + A2 (2013) (class TBTS)	Safety of information technology equipment, including office hardware, TBTS class.
LVD Safety	EN 62368-1 (2014)	Audio/video, information and communication technology equipment Part 1: Safety requirements

Table 11.6: Safety standards

11.4.2 EMC standards

The standards for the electromagnetic compatibility (EMC) are:

Section	Standard number	Title/Content
Immunity	EN 61000-6-1 (2007)	Immunity for residential, commercial and light-industrial environments (generic standard)
Immunity	EN 61000-6-2 (2005)	Immunity standard for industrial environments (generic standard)
Emissions	EN 61000-6-3 (2007)	Emission standard for residential, commercial and light-industrial environments (generic standard)
Emissions	EN 61000-6-4 (2007) + A1 (2011)	Emission standard for industrial environments (generic standard)
Emissions	EN 61000-3-2 (2014) (class A)	Limits for harmonic current emissions (equipment input current ≤ 16 A per phase)
Emissions	EN 55032 (2015) (class B)	Electromagnetic Compatibility of Multimedia Equipment

Table 11.7: EMC standards

11.4.1 IEEE standards

The standards for local and metropolitan area networks are:

Standard number	Content
IEEE 802.1D	Standard Spanning Tree / Multicast
IEEE 802.1w	Rapid Spanning Tree (RSTP)
IEEE 802.1Q	VLAN
IEEE 802.1X	Radius
IEEE 802.3ad	Link Aggregation Control Protocol (LACP)
IEEE 802.3i	10BaseT
IEEE 802.3u	100BaseT(X) and 100BaseFX
IEEE 802.3ab	1000BaseT(X)
IEEE 802.3z	1000BaseX
IEEE 802.3x	Flow Control
IEEE 802.3af	PoE
IEEE 802.3at	PoE+
IEEE 802.3bt	HiPoE
IEEE 802.3az	Energy Efficient Ethernet

Table 11.8: IEEE standards

11.4.2 Transportation standards

To ensure the safety of the lithium batteries during the transportation, the batteries are certified UN 38.3.

12. Warranty and Product Returns

12.1 Warranty

The equipment is guaranteed for three years from the date of delivery (ex-works). It is strictly limited to reimbursement or replacement (at our discretion and without compensation of any sort) of parts recognized as faulty by our services, following the return of the product to our premises at the buyer's expense. The replacement or repair of equipment is possible only on our premises. In order to allow our customers to benefit from the latest technical improvements, SLAT reserves the right to make all necessary modifications to its products.



12.2 Product Returns

12.2.1 Product under warranty

For the maintenance of your products under warranty, SLAT offer the best solution to facilitate your repairs and minimize lead times:

- Contact the Customer Service department using the form available on our web site www.slat.com , taking care to fill in all the required fields.
- The RMA form will be processed and sent back by the SLAT account manager.
- After receiving your RMA form, return two copies with your product(s), one INSIDE the package and the other on the OUTSIDE of the package for warehouse identification purposes, thereby guaranteeing traceability of your product.
- The repaired or replaced product(s) will be returned within a maximum of 15 business days.

12.2.2 Product not under warranty

Product repair by SLAT

Contact Customer Service at service.client@slat.fr, making sure to provide all of the following information:

- Last name/First Name
- Company / Complete Address / Phone / Email
- Exact model of the product (indicated on the product label) / SLAT reference (indicated on the product label, code number) / Serial No. / Quantity / Problems(s) encountered (describe the faults encountered with the product)

The form to request the RMA number is also available at www.slat.com.

The account manager will send the RMA form by email together with a quote according to the relevant product range.

After receiving your RMA form, return two copies with your product(s), one INSIDE the package and the other on the OUTSIDE of the package for warehouse identification purposes, thereby guaranteeing traceability of your product. The repairs will be made only after the receipt of the accepted quote together with the repair order form. If the quote is rejected, please return it to service.client@slat.fr marked "refused" and specify whether the equipment should be destroyed or returned in its existing condition (in this case a charge of €150 will be invoiced for handling costs).

The repaired or replaced product(s) will be returned within a maximum of 15 business days. A new 3 month warranty is attributed to the relevant product.

Conditions: Authorization to return products is issued by SLAT.

An RMA number is assigned to each product to be returned. Each RMA number is valid for 30 days.

No equipment may be returned without prior issuance of an RMA number.



SLAT

11, Rue Jean Elysée Dupuy BP66
69543 Champagne au Mont d'Or Cedex
FRANCE

Tel.: +33 478 66 63 60

Fax: +33 478 47 54 33

e-mail: comm@slat.fr

SLAT GmbH

Leitzstraße 45
70469 Stuttgart
DEUTSCHLAND

Tel.: +49 711 899 890 08

Fax: +49 711 899 890 90

E-mail: info@slat-gmbh.de



www.slat.com