

SYNAPS

Network connection interface

SYNAPS POE5F V 8P2F C



SLAT SAS

11 rue Jean Elysée Dupuy - BP66
69543 Champagne au Mont d'or - France
+33 4 78 66 63 70
comm@slat.fr
www.slat.com

SLAT GmbH

Leitzstraße 45
70469 Stuttgart – Deutschland
+49 711 899 890 92
info@slat-gmbh.de
www.slat.com

TABLE OF CONTENTS

TABLE OF CONTENTS	2
1 LIST OF PRODUCT DESIGNATIONS	4
2 SAFETY	4
3 DEFINITION OF SYMBOLS	5
4 GENERAL INFORMATION	6
4-1 THE COMPANY	6
4-2 PURPOSE OF THESE INSTRUCTIONS.....	6
4-3 RELATED DOCUMENTATION	6
4-4 INTENDED AUDIENCE.....	6
4-5 TYPES OF NOTIFICATION	6
5 THE PRODUCT.....	7
5-1 DESCRIPTION	7
5-2 SCHEMATIC DIAGRAM	7
5-3 PRODUCT VIEWS.....	8
5-4 CONTENTS OF THE DELIVERY	9
6 INSTALLING THE CABINET	10
6-1 WALL-MOUNTING OR PULL BOX-MOUNTING	10
6-2 POLE-MOUNTING.....	10
6-3 MECHANICAL SPECIFICATIONS	11
7 FIXING ACCESSORIES	12
8 CONNECTING TO THE MAINS	13
8-1 RECOMMENDATIONS	13
8-2 WIRING METHODS.....	13
8-3 CONNECTION	13
9 CONNECTING TO THE NETWORK.....	14
9-1 RECOMMENDATIONS	14
9-2 WIRING METHODS.....	14
9-3 ETHERNET NETWORK CHARACTERISTICS	14
9-4 ELECTRICAL AND COMMUNICATION OUTPUT SPECIFICATIONS.....	14
9-5 INPUT FAULT AND ALARMS REPORT BY DRY CONTACT	15
9-6 NETWORK PROTECTION PROTOCOLS	15
9-7 INSTALLING THE ROOT CERTIFICATE	15
9-8 ASSIGNING AN IP ADDRESS.....	16
10 SYNAPS BACKUP	17
10-1 AVAILABLE STORAGE OPTION.....	17
10-2 DESCRIPTION	17
10-3 OPERATING PRINCIPLE.....	17

10-4	TECHNOLOGY.....	17
10-5	AUTONOMY CURVE AND DURATION.....	18
11	EMBEDDED WEBSERVER.....	19
11-1	LOGIN PAGE - LOGGING ONTO THE PRODUCT.....	19
11-2	WEB-BASED USER INTERFACE – DESCRIPTION.....	19
11-3	HEADLINE.....	20
11-4	CONFIGURATION AND OPERATION OF THE SWITCH.....	20
11-5	REBOOT DEVICE.....	21
11-6	FACTORY CONFIGURATION RESET.....	21
11-7	PRODUCT SWITCH-OFF.....	21
12	OPERATION.....	22
12-1	LOCAL REPORT ON PRODUCT.....	22
12-2	INPUT FAULT AND ALARMS REPORT BY DRY CONTACT.....	23
12-3	REMOTE REPORT - COMMUNICATION.....	23
A.	ACCESSIBLE DATA.....	24
B.	HTTPS PROTOCOL.....	25
C.	SNMP PROTOCOL.....	26
D.	BACNET IP PROTOCOL.....	27
13	TECHNICAL DATA.....	33
13-1	MAINS INPUT ELECTRICAL CHARACTERISTICS.....	33
13-2	POE ELECTRICAL CHARACTERISTICS.....	33
13-3	FUNCTIONAL CHARACTERISTICS.....	34
13-4	ENVIRONMENTAL SPECIFICATIONS.....	34
13-5	SAFETY STANDARDS.....	34
13-6	EMC STANDARDS.....	35
13-7	IEEE STANDARDS.....	35
14	MAINTENANCE AND TROUBLESHOOTING.....	36
14-1	MAINTENANCE.....	36
14-2	TROUBLESHOOTING.....	36
15	WARRANTY AND PRODUCT RETURNS.....	37
15-1	WARRANTY.....	37
15-2	PRODUCT RETURNS.....	37
15-3	PRODUCT NOT UNDER WARRANTY.....	37

1 LIST OF PRODUCT DESIGNATIONS

These operating instructions apply to all the products listed in the table below.

Table 1-1 - List of product designations

DESIGNATION	CODE
SYNAPS POE5F V 8P2F C	700210013

2 SAFETY

This manual contains all the instructions to follow to install, commission and use the SYNAPS network connection interface. Please follow them very carefully to ensure the product functions correctly. It is vital to read the Safety Instructions before installing or commissioning this product.

SAFETY INSTRUCTIONS

SYNAPS is designed to be connected to the 110 - 240 V AC public mains supply which has a frequency of 45 to 65 Hz.

- ➔ A disconnect switch or circuit breaker must be installed upstream in accordance with the current regulations.
- ➔ To avoid any risk of electrocution, the disconnect switch or circuit breaker must be opened before any maintenance work is carried out on the equipment.
- ➔ Work must only be carried out by qualified personnel.
- ➔ During installation, connect the ground first and when dismantling, disconnect it last.
- ➔ Ensure the product is the right way round (see photo on page one of the chapter entitled "Product Installation")
- ➔ EN 62368-1 compliance (This equipment is not suitable for use in places where children are likely to be present).
- ➔ Provide sufficient convection (clearance of at least 50 mm).
- ➔ The equipment is only designed to be installed or mounted on a non-combustible surface.
- ➔ Size and protect the cables in accordance with the maximum input / output current ($\geq 0.15 \text{ mm}^2/\text{A}$).
- ➔ Observe the thermal and mechanical limits.
- ➔ Caution! There is a risk of explosion if the battery is not an original part supplied by SLAT!
- ➔ Recycle the product and its battery at the end of its life in accordance with the instructions.
- ➔ The backup is maintenance-free. Do not open it.
- ➔ In case of extended storage or disconnection, switch off the mains power supply and follow the procedure described in the "Product shutdown" paragraph in the chapter entitled "Embedded webserver".

3 DEFINITION OF SYMBOLS



Compliance of the product with the requirements of the European directives.



WEEE (WASTE ELECTRICAL AND ELECTRONIC EQUIPMENT)

Dispose of the product in an appropriate recovery and recycling centre.
This product must not be disposed of with the household waste.



RoHS (RESTRICTION OF HAZARDOUS SUBSTANCES)

Compliance with the European directive restricting the use of certain hazardous substances in electrical and electronic equipment.



Protective ground terminal.



Caution, risk of electric shock.



The product must be recycled at the end of its life. The various components can be easily separated. A plug-in connector allows the backup to be easily removed by qualified professionals independent of SLAT.

SLAT is committed to protecting the environment and public health. SLAT designs and manufactures all its products in line with the RoHS and WEEE environmental directives.

4 GENERAL INFORMATION

4-1 THE COMPANY

To better satisfy its customers' expectations:

- SLAT designs and manufactures all its products according to standard ISO 14001 v15.
- SLAT recycles its products at the end of their life cycle by means of its recycling programme.

4-2 PURPOSE OF THESE INSTRUCTIONS

These operating instructions provide the information necessary to set up, connect, configure and operate the SYNAPS POE5F V 8P2F C equipment.

These instructions are also available in PDF format from the MySLAT space at www.slat.com.

4-3 RELATED DOCUMENTATION

The following documents are related to these operating instructions:

- Installation manual
- Commercial brochure

This documentation is available at www.slat.com.

4-4 INTENDED AUDIENCE

The operations and information described in these instructions must only be performed by authorised, trained operators.

4-5 TYPES OF NOTIFICATION

Three types of important notifications are used in these instructions. The type of notification informs you of the potential consequences of non-compliance with the instructions.

These consequences are not exhaustive and are listed in order of increasing risk.



IMPORTANT REMARK!

Contains additional information. Non-compliance will not cause damage to equipment or injury.



CAUTION!

Equipment and property may be seriously damaged or people may be seriously injured if the precautions for use are not followed.



DANGER!

Failure to comply with the notification may lead to serious injury or death.

5 THE PRODUCT

5-1 DESCRIPTION

SYNAPS POE5F V 8P2F C is a network connection interface.

SYNAPS is installed as close as possible to the applications and offers every benefit to optimise wiring. It also enables selective electrical protection of the applications.

The benefits of SYNAPS

- Eliminates brown-outs and provides emergency power appropriate to your needs.
- Protects equipment against lightning and electromagnetic disturbances.
- Designed for outdoor use, with IP65 watertight and IK10 vandalism-proof locked cabinet.
- Ultra compact and lightweight product.
- Monitoring by secure protocols: HTTPS / SNMP V1, V2c and V3 / BACnet IP.



- Eliminates brown-outs and provides emergency power appropriate to your needs.

5-2 SCHEMATIC DIAGRAM

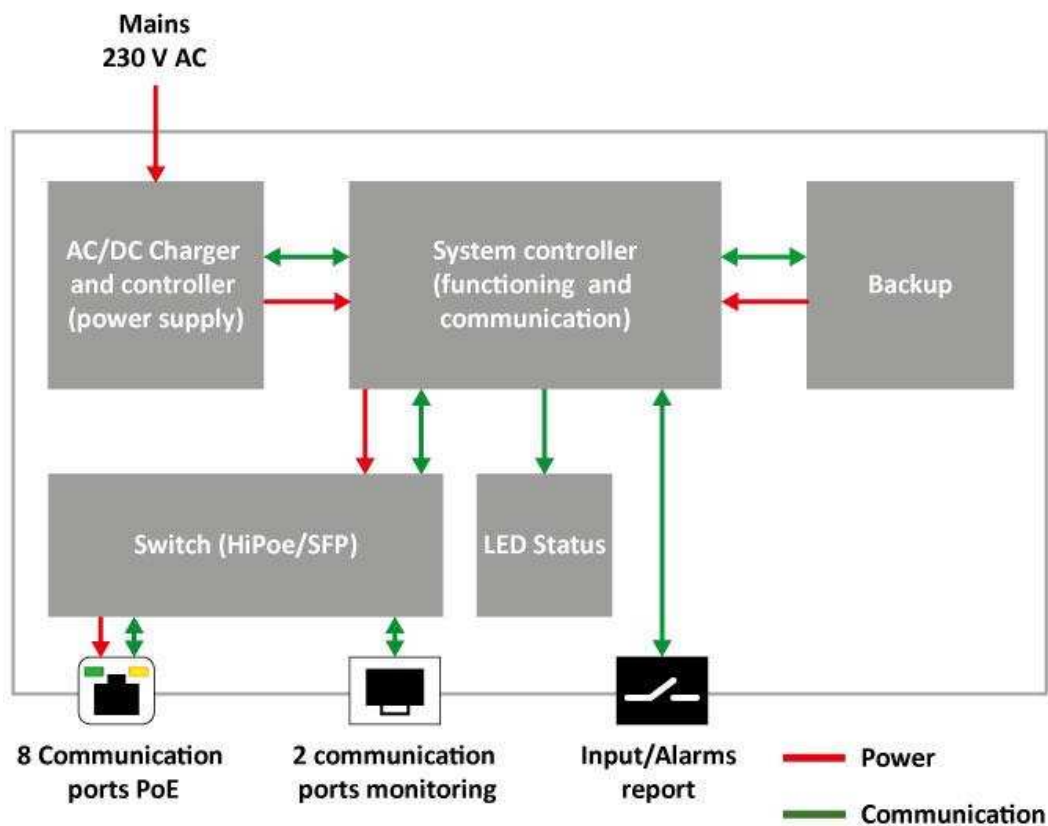

5-3 PRODUCT VIEWS

Exterior
Interior

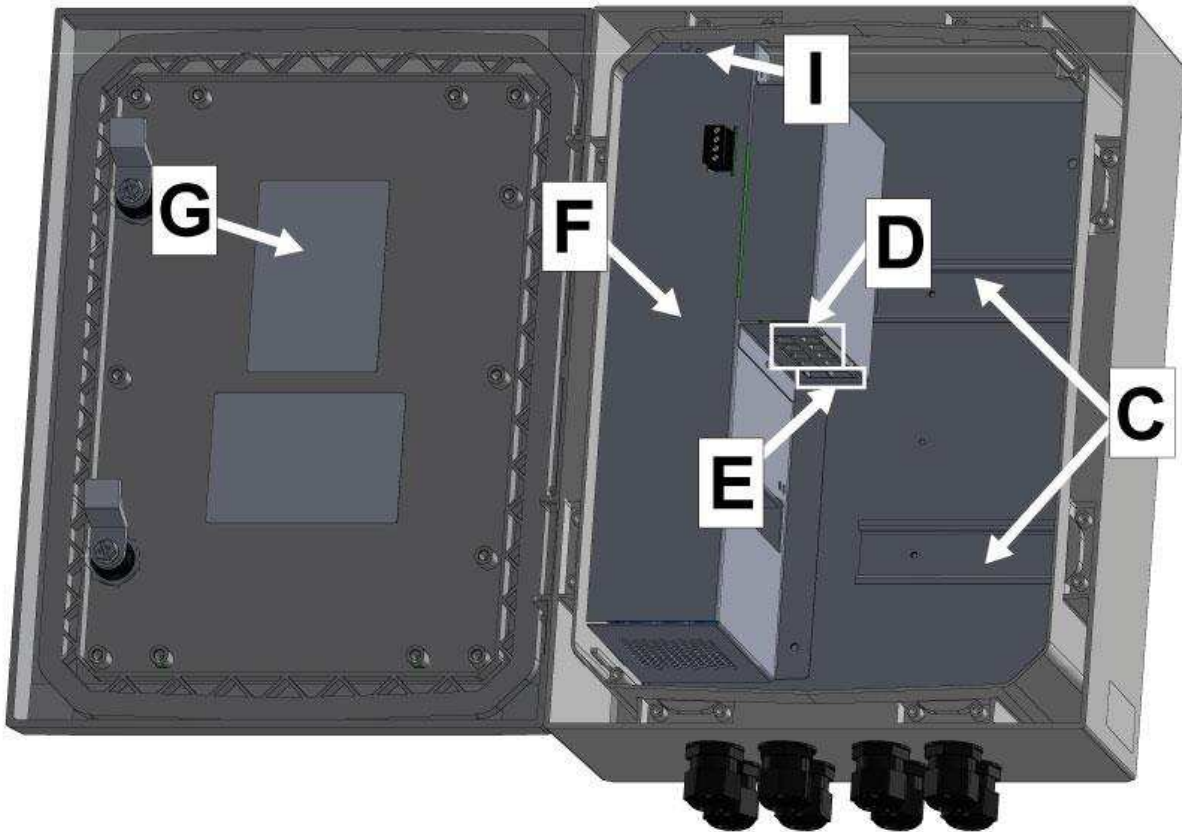
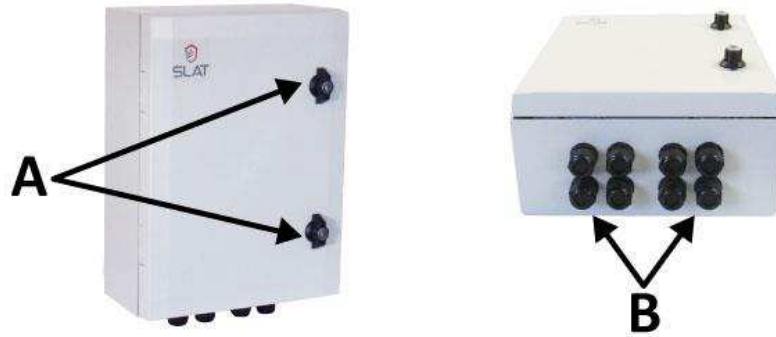

H

surge arrester

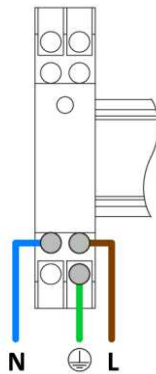

Location and legend of components

	NAME	USE
A	Handle with key lock	Door opening vs closing and protection with key.
B	Cable gland	Cable feedthrough for all cables including RJ45 cables.
C	DIN rail	Mounting of customer equipment.
D	Ethernet ports (PoE/POE+)	The communication uses an Ethernet connection and the SNMP, HTTPS or BACnet IP protocol to retrieve detailed product information (10/100 Mbps/1 Gbps). Using this port, the Ethernet connection supplies over PoE/PoE+/HiPoE the connected device.
E	SFP Ports	Communication uses a SFP module connection and SNMP, HTTPS and BACnet IP protocols to retrieve detailed information about the product (100 Mbps/1 Gbps).
F	MAC address	Identifies the SYNAPS over the Ethernet network.
G	Connection label	Location of connection points and the backup disconnect button for extended storage.
H	Mains	220 - 240 V AC mains input.
I	Push-button	Reboot/Reset (mains present) / Battery disconnection (no mains present).

5-4 CONTENTS OF THE DELIVERY

The product is delivered with:

- ➡ The installation manual

6 INSTALLING THE CABINET

The product must be installed according to safety standard EN 62368-1. It can be installed in an unventilated area.

The SYNAPS POE5F V 8P2F C is designed to be installed vertically on a wall, in a pull-box or on a pole.

6-1 WALL-MOUNTING OR PULL BOX-MOUNTING

1. Place the product against the wall (on a concrete substrate for example) and mark the fastening points or use the dimensions stated in this manual (holes for 4 screws).
2. Drill the substrate and insert 4 plugs (not supplied – \varnothing 6 x 50 mm recommended).
3. Attach the product using 4 screws (not supplied – \varnothing 5 x 50 mm recommended).
4. Use washers with a diameter of 10 mm.

Cooling the product by natural convection requires a minimum clearance of 50 mm on each side.

The figure opposite shows how the cabinet should be positioned after mounting on the wall.

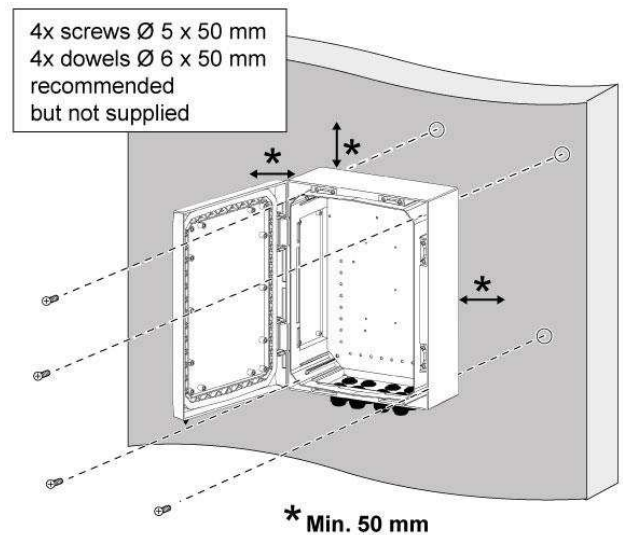

6-2 POLE-MOUNTING

1. Mount the kit on the product using a bit screwdriver [$\frac{1}{4}$ " socket and $\frac{1}{4}$ " hex bit (H6)].
2. Attach the product to the pole using the clamp (\varnothing min. 100 – max. 300 mm).

The figure opposite illustrates how the mounting kit should be fitted to the cabinet and positioned on the pole.

The installer is responsible for checking the load capacity of the pole.

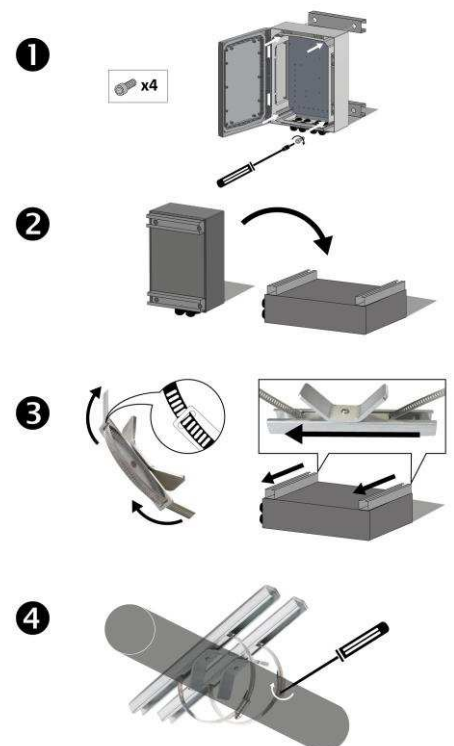

6-3 MECHANICAL SPECIFICATIONS

MECHANICAL SPECIFICATIONS	
Cabinet	Polycarbonate
Protection rating	IP 65
Impact resistance	IK10
Dimensions (cabinet)	L 300 x H 400 x D 150 mm
Overall dimensions	L 300 x H 432 x D 171 mm
Available customer space 1	L 114 x H 160 x D 115 mm
Available customer space 2	L 130 x H 160 x D 115 mm
Weight	6,9 kg
SCx (air resistance)	0.132
Installation	Wall-, pull box- or pole-mounted box

7 FIXING ACCESSORIES

- ➔ The pole mounting kit (optional)



- ➔ The wall mounting kit (optional)



8 CONNECTING TO THE MAINS

8-1 RECOMMENDATIONS

- Network voltage: 220/240 VAC (198-264 VAC).
- Frequency: 50-60 Hz (45-65 Hz).
- Class I.
- Neutral systems: TT, TN, IT.
- Circuit breaker recommended upstream: curve D (rating 4 A).
- Primary current:
@ 230 VAC : 2,1 A
@ 195,5 VAC : 1,7 A @ 264,5 VAC : 1,85 A

Surge arrester: type 2 -10 kA

Cable cross-section 0.3 to 2.5 mm² - Length to be stripped 7 mm - tightening torque 0.5 to 0.6 N.m.



DANGER!

The cable cross-section used must be selected according to the operating current. ($\geq 0.15 \text{ mm}^2/\text{A}$)

8-2 WIRING METHODS

Connect the cables according to the symbols on the label (flat screwdriver).



CAUTION!

Comply with the recommended screw tightening torque to avoid breaking the equipment.

Make a careful note of the positioning of the pieces of equipment and their respective symbols to avoid any wiring mistakes.

Altering the pre-wiring on the product could cause it to malfunction and would invalidate the warranty.

8-3 CONNECTION



DANGER!

The application must be switched off in order to connect the equipment.

The circuit breaker upstream of the application must be open!

The stripped parts of the mains cables must be crimped before being connected to the product terminals!

Always connect the ground wire first before connecting the power supply to the mains!

The mains input cables must be connected to the surge arrester. Connect the three wires according their colour:

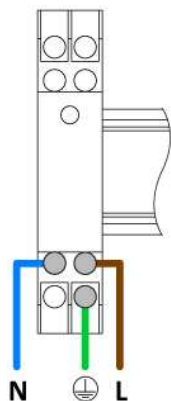

Yellow/green - ground wire

Blue - neutral wire (N)

Brown - live wire (L)

After connecting the ground wire, the "neutral" and "live" wires can be connected.

9 CONNECTING TO THE NETWORK

9-1 RECOMMENDATIONS

The Ethernet cable must have the following properties:

Ethernet cable - shielded or unshielded - straight or crossed cables - Cat. 5 or more.

The SFP modules ports (100/1000 Mbps) are auto MDI-X, that either straight-through or twisted cables can be used.

9-2 WIRING METHODS

The communication cables are connected to the product by Ethernet ports. They are auto MDI-X ports so straight or crossed cables can be used.



CAUTION!

Make a careful note of the positioning of the connectors to avoid any wiring mistakes.

Altering the pre-wiring on the product could cause it to malfunction and would invalidate the warranty.

Connect the top-hand Ethernet ports to the applications

The product is connected to the PoE/PoE+/HiPoE applications by the Ethernet ports 1 to 4 and the PoE/PoE+ applications by the Ethernet ports 5 to 8. This connection allows to supply the application, when it is PoE compatible [the output voltage is set in accordance to the PoE standards (IEEE 802.3af/802.3at/802.3bt)]. It also allows communication with the application.

Connect the bottom-hand Ethernet port to the supervisor

The SYNAPS POE5F V 8P2F C is connected to the supervisor by the bottom hand SFP module port.

This connection creates the link with the supervisor for remote management.

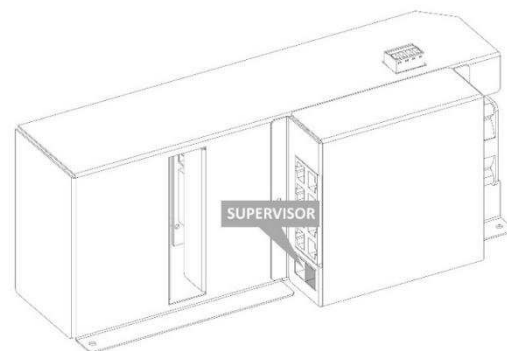

Information concerning communication:

The communication speed of the Ethernet port(s) with PoE/PoE+/HiPoE operation on the top-hand side is 10/100 Mbps /1 Gbps.

The communication speed of the SFP module port on the bottom-hand side is 100 Mbps/1 Gbps.

9-3 ETHERNET NETWORK CHARACTERISTICS

Before starting to commission the power supply, check that the UPS DC Status LED is green. This means that the product is correctly powered and ready to function.

The communication parameters can be configured via the HTTPS website. It can also be used to configure energy saving mode (ECO) and stealth mode. In order to communicate with the product, it must be configured according to the following chapters.

The configuration of the network of the computer to which the product will be connected must be compatible with the product's network parameters.

9-4 ELECTRICAL AND COMMUNICATION OUTPUT SPECIFICATIONS

Electrical outputs

- Port PoE + (IEEE 802.3at) 1 Gbps : 4
- Port HiPoE + (IEEE 802.3bt type 4) 1 Gbps : 4

Communication outputs

- Port fibre 1 Gbps : 2

9-5 INPUT FAULT AND ALARMS REPORT BY DRY CONTACT

Input fault by dry contact (Digital Input)

An input is available for customer applications and allows the transmission of information by dry contact (e.g. door opening control, lightning arrester, fire detection...).

Alarms report by dry contact NC

Alarms can be reported by dry contact (positive safety contact: coils activated without default). You can choose the type of alarm report on the embedded website in the "Alarms" section.

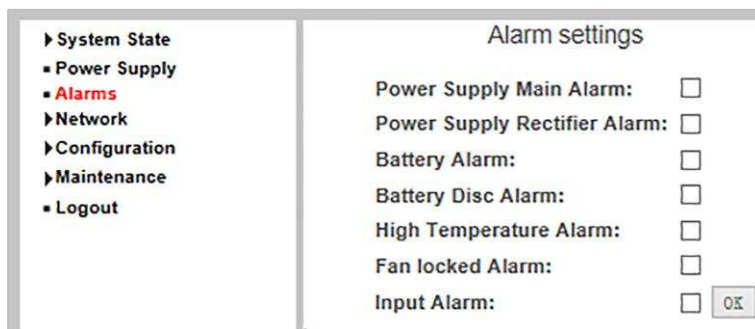

9-6 NETWORK PROTECTION PROTOCOLS

The product supports the following communication protocols. They can run simultaneously. Therefore it is not necessary to select a single active protocol.

Application protocols: HTTPS BACnet IP DHCP SNMP v1, v2c + v3
Network protocols: IPv4 ICMP

9-7 INSTALLING THE ROOT CERTIFICATE

To use the products in HTTPS and communicate safely with them the SLAT root certificate must be installed on the user's computer. This certificate is valid for all SLAT products and can be downloaded from MySLAT on www.slat.com.

The root certificate is called SLAT_ca_cert.crt

The certificate must be installed in the certificate store: "Trusted root certification authorities".

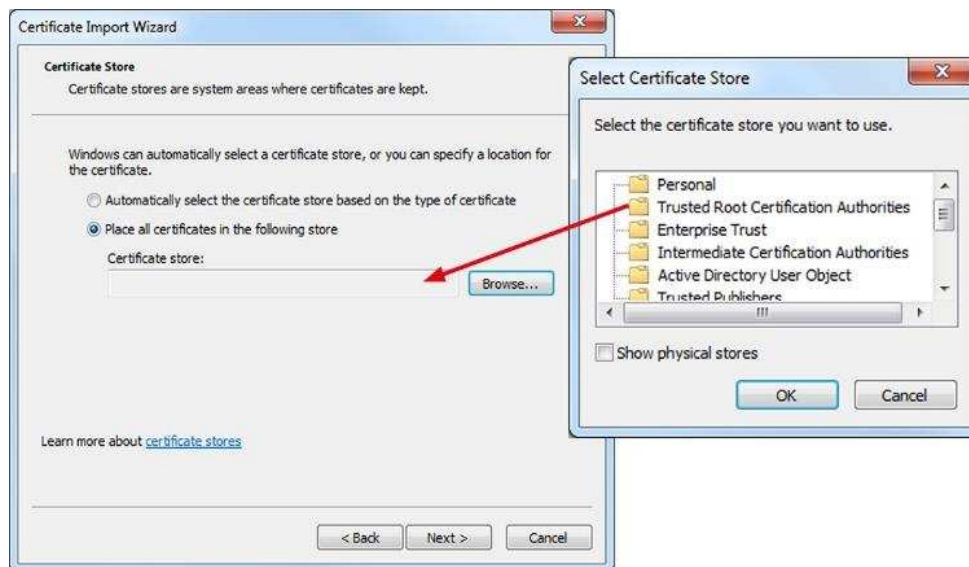

Selecting the certificate store

9-8 ASSIGNING AN IP ADDRESS

The DHCP (dynamic IP address allocation) automatically assigns an IP address to a product in order to communicate with it. This feature is enabled by default in the factory configuration.

There are two operating modes depending on the availability or lack of a DHCP server on the network:

A. DHCP server available

If a DHCP server is available, it allocates an IP address to the product. If several products are connected to the network, it allocates a different IP address to each one.

Browse the network to determine the new address.

B. DHCP server unavailable

If no DHCP server is available on the network, the product uses the IP parameters below. When the product connects to the network for the first time, it remains in DHCP for 1 minute before switching to the predefined IP address.

➡ IP address **192.168.1.1** ➡ IP address **No gateway**
➡ Network mask **255.255.255.0**

In this case, if several products need to be connected to the same network, as they all have the same IP parameters, they must be isolated and the IP address of each product must be modified with the HTTPS web interface before being connected to the network in order to avoid any IP address conflicts. The same procedure is valid if the same IP address exists several times on a given network. See the chapter entitled “Embedded webserver” to change the IP address.

10 SYNAPS BACKUP

10-1 AVAILABLE STORAGE OPTION

SLAT products are combined with backup systems. They are used as emergency power supplies if the mains supply is cut off. The available autonomy then depends on the capacity of the built-in backup.

The backup (Smart Backup Inside) integrated into the SYNAPS POE5F V 8P2F C represents a minimum guaranteed power supply of 60Wh.

10-2 DESCRIPTION

SYNAPS POE5F V 8P2F C with “Smart Backup Inside” is lead-free, cadmium-free and has a very long service life.

The built-in Li-ion backup (Micro-UPS DC - Uninterruptible Power Supply) for security systems. In the event of a power outage or glitch, it ensures continuity of service for the equipment it powers with its integrated backup function and maintains communication with the supervisor.

Built-in functions

- Keeps control of sensitive building and infrastructure equipment during power outages and glitches.
- Avoids false alarms being reported to the supervisor due to network glitches.
- Delivers a constant voltage to the equipment.
- Operates in power-saving mode when the backup is charged.
- Indicates the % remaining autonomy.

10-3 OPERATING PRINCIPLE

When connected to the mains, the UPS DC SYNAPS stores energy and continuously powers the connected devices.

During glitches or when the mains supply fails, the built-in emergency supply continues to provide power to the connected devices without interruption.

In the event of a complete discharge, the recharging time to 100% of the backup will in all cases be less than 20 hours of mains presence.

10-4 TECHNOLOGY

The SYNAPS POE5F V 8P2F C backup system uses lithium iron phosphate technology (LiFePO₄). LiFePO₄ offers the best safety characteristics of any lithium storage system (see illustration below). This includes better resistance to impacts and to extreme temperatures.

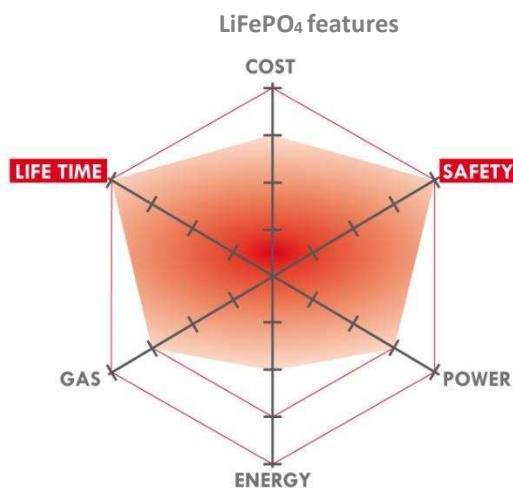

The SYNAPS POE5F V 8P2F C backup has the following features:

- ➔ Lithium iron phosphate technology (LiFePO₄)
- ➔ No risk of thermal runaway
- ➔ Storage for 9 months without recharging
- ➔ 10-Year service life at 25°C
- ➔ Lead-free, cadmium-free, 100% recyclable

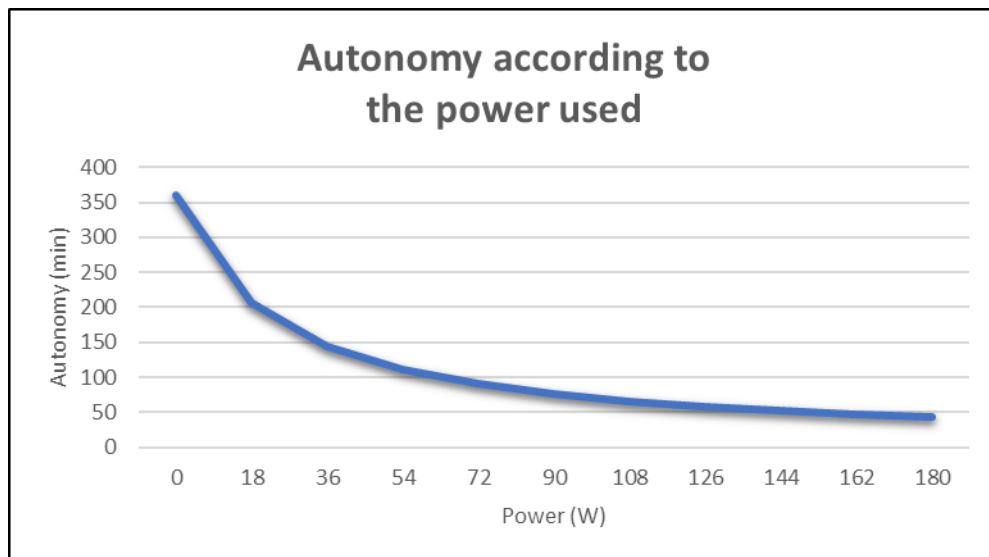
10-5 AUTONOMY CURVE AND DURATION

11 EMBEDDED WEBSERVER

The communication parameters can be configured via the HTTPS website. It can also be used to configure energy saving mode (ECO) and stealth mode.

In order to communicate with the product, it must be configured according to the following chapters. The configuration of the network of the computer to which the product will be connected must be compatible with the product's network parameters.

11-1 LOGIN PAGE - LOGGING ONTO THE PRODUCT

Login page

You can log onto the product using a web browser (over HTTPS) using the allocated or predefined IP address. The language used is that of the web browser.



IMPORTANT REMARK!

The default login and password are:

Login: admin

There is no password. Click directly on "OK".

It is essential to set a password for the security of your installation!

11-2 WEB-BASED USER INTERFACE – DESCRIPTION



After entering the login and the password in the login page and once connection with the product has been established, the "System Information" page of the section "System State" is displayed.

The user interface is divided in three areas: headline, main menu and main screen.

System	
Product Name	SDC-POE 5F DIN4 8P2F
Serial Number	12345678
MAC Address	00:04:f3:15:fb:69
Location	E11
Contact	after.sales@slat.fr
Time	
System Date	23/03/2020
System Time	16:33:18
System Uptime	5h 53min 39s

11-3 HEADLINE

The headline is the area on top of each page. It is the same for each page of the menu. In the center, it contains the product's name defined in the "Settings Configuration" page as well as the port indicators and the PoE LEDs. The featured port numbers in the headline correspond to the numbers on the switch. The colors of the port indicators inform about the link working status.

-  link 10/100 Mbps (yellow)
-  link 1000 Mbps (green)
-  no link (black)

The PoE LED symbols to the left of the 2x4 RJ45 connector block symbol indicate the status of the PoE power supply.

- Blue – powered over PoE
- Red – fault on the PoE
- White – no powered PoE

The user can send an email to SLAT's after-sales service thanks to the "Support" link, located on the right side of the headline.

Main menu

The main menu is situated on the left side of the interface. It gives an overview of the different sections and allows access to all the pages of this site. The pages are organized in the following sections:

- System State
- Power Supply
- Alarms
- Network
- Configuration
- Maintenance
- Logout

Main screen

The main screen will occupy most of the screen space and will contain the relevant information for the section selected. Depending on the page, the user has access to either information or configurable parameters.

11-4 CONFIGURATION AND OPERATION OF THE SWITCH

The switch's functions can be set up and the operating of the switch can be supervised via the embedded website. Information regarding the configuration of the switch functionalities and the operation of the switch can be found in the "advanced user's manual". It can be downloaded in MySLAT at www.slat.com.

11-5 REBOOT DEVICE

The reboot can be performed on the onboard website or on the product

Via the onboard website

To reboot the product (Reboot device) select "Reboot device" in the maintenance section of the maintenance page. Click on "yes" in "Reboot device" and wait for the end of the countdown (120 seconds). Once rebooted, the return to the page "system information" is automatic.



On the product

The "PoE Load" and "Status" LEDs turn off for a few seconds and then light green until restart. The total duration of the restart is 2 minutes.

11-6 FACTORY CONFIGURATION RESET

The reset can be performed on the onboard website or on the product.

Via the onboard website

To reset the product (Factory reset) select "Factory reset" in the maintenance section of the maintenance page. Click on "yes" in "Factory reset" and wait for the end of the countdown (120 seconds). Once the reset is complete, the return to the "login" page is automatic. You have to log in again as described in chapter 11-1 on page 19.

The "PoE Load" and "Status" LEDs will go out for a few seconds and then light green until restart. The total duration of the restart is 2 minutes.



On the product

The reset consists of configuring the product with factory parameters. This reset is done by pressing the reboot/Reset in the front. When the led « status » are blinking green/red release the button, the reset is complete.

11-7 PRODUCT SWITCH-OFF

To stop and switch-off the product, It's necessary to:

- Disconnect the network cables.
- Disconnect the mains.
- Wait one (1) minute until the product has shut down.

12 OPERATION

During use, it is possible to interact with the product. There are two types of communication: local report and/or remote report.

12-1 LOCAL REPORT ON PRODUCT

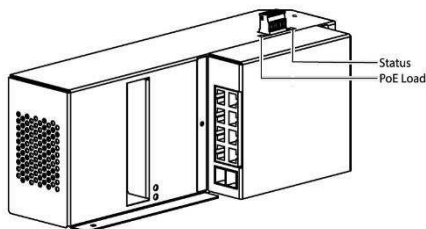

“Status” LED

The product communicates its status via a Status LED on the front. The LED indicates the different statuses of the product by its color and state. The table explains the meanings of each state.

COLOR AND STATE	MODE	
Green	steady	Normal mode without fault
	slow flashing	Eco Mode or Stealth Mode
Orange	slow flashing	Backup mode
	fast flashing	Mains outside specified power supply range
		Installation fault
Red	steady	End of backup or stop imminent
		Change product
	If product out of order (charger fault)	Fan rotor locked
		Temperature sensor failure or disconnected
		Communication Failure with the Power Supply
		Communication Failure with the Switch
Backup alarm		

“PoE Load” LED

The product communicates the PoE load level via the PoE Load LED on the front. The LED indicates the different power levels of the PoE load by its color. The table explains the meanings of each color.

COLOR	MODE	
Green	steady	Power <= 80%
Orange	steady	80% < Power <= 100%
Red	steady	100% < Power or boost DC/DC failure

PoE LED (RJ45)

The product indicates the state of the PoE/PoE+/HiPoE supply of the Ports 1 to 4 and PoE/PoE+ supply of the Ports 4 to 8 via the LEDs at the bottom of each one of these ports. When the application, which is connected to one of the ports, is supplied via PoE, the corresponding LED shines green.

Link LED (RJ45)

The product indicates the Ethernet connection status of an application to the Ports 1 to 4 via the LEDs on the top of each one of these ports. When a connection between an application and a port is established, the port's Link LED shines.

COLOR	MODE	
Yellow	steady	Connection established
	flashing	Connection established and activity on the line

12-2 INPUT FAULT AND ALARMS REPORT BY DRY CONTACT

Input fault by dry contact (Digital Input)

An input is available for customer applications and allows the transmission of information by dry contact (e.g. door opening control, lightning arrester, fire detection...).

Alarms report by dry contact NC

Alarms can be reported by dry contact (positive safety contact: coils activated without default). You can choose the type of alarm report on the embedded website in the "Alarms" section.

12-3 REMOTE REPORT - COMMUNICATION

When using the product, it is possible to communicate with it remotely using the built-in communication system. The Ethernet connection makes it possible to:

- ➔ retrieve information remotely
- ➔ have more details about the types of faults
- ➔ communicate analogue values (user voltages and currents, remaining backup percentage, internal temperature, autonomy)
- ➔ configure the power supply

The product communicates its information on the Ethernet connection via the HTTPS, SNMP and BACnet IP application protocols.

The information and explanations on how to configure the product are described in the chapter entitled "Embedded webserver". The following chapters describe the information available via the different protocols.

A. ACCESSIBLE DATA

The following data is accessible over SNMP and BACnet IP.

Details of the "System state" variable

BIT	NAME	DESCRIPTION
27 - 31	- Reserved -	-
26	Ethernet fault	In read mode, if the bit is at 1, then one or more Ethernet links have been lost. The fault remains active even if the links are restored. To acknowledge the fault, set the bit to 1 in write mode, which then switches to 0 in read mode.
25	Halt stealth mode	Set bit to 1 in write mode to stop stealth mode. The bit remains at 0 in read mode.
24	Stealth mode start / status	In read mode, if the bit is at 1, then stealth mode is enabled. Set bit to 1 in write mode to start stealth mode.
20 - 23	- Reserved -	-
19	Communication fault	Internal communication error if the bit is at 1. The values of the read data are not significant.
18	Initialisation fault	Initialisation of the internal communication in progress if the bit is at 1. The values of the read data are not significant.
16 - 17	- Reserved -	-
15	High battery current	If the bit is at 1, then the battery current is too high.
14	High battery voltage	If the bit is at 1, the product must be replaced: the battery voltage is too high.
13	End of autonomy	End of autonomy pre-alarm when the bit is at 1 (shutdown is imminent).
12	Battery fault	If the bit is at 1, the product must be replaced: the battery is faulty or has been removed.
11	Rectifier fault	If the bit is at 1, the product must be replaced: the charging system is faulty and the battery may not be charged.
10	Mains fault	If the bit is at 1, mains power is absent.
9	Output overload	If the bit is at 1, the output is overloaded.
8	Output short circuit	If the bit is at 1, the output is short-circuited.
7	High temperature	If the bit is at 1, the temperature in the product is too high.
6	Battery disconnection	If the bit is at 1, the battery is disconnected.
5	Stealth mode or eco mode	If the bit is at 1, stealth mode or eco mode is activated.
4	Intrusion detection	When the option is present, if the bit is at 1, box tampering or removal detection is enabled.
0 - 3	- Reserved -	-

Details of the “System state” variable

BIT	NAME	DESCRIPTION																		
26 - 31	- Reserved -	-																		
24 - 25	Ethernet State	Ethernet port state: <table border="1"> <thead> <tr> <th>VALUE</th> <th>STATE</th> </tr> </thead> <tbody> <tr> <td>00</td> <td>No link</td> </tr> <tr> <td>01</td> <td>10 Mbps link</td> </tr> <tr> <td>10</td> <td>100 Mbps link</td> </tr> <tr> <td>11</td> <td>1000 Mbps link</td> </tr> </tbody> </table>	VALUE	STATE	00	No link	01	10 Mbps link	10	100 Mbps link	11	1000 Mbps link								
VALUE	STATE																			
00	No link																			
01	10 Mbps link																			
10	100 Mbps link																			
11	1000 Mbps link																			
23	- Reserved -	-																		
20 - 22	PoE Class	PoE Class: <table border="1"> <thead> <tr> <th>VALUE</th> <th>STATE</th> </tr> </thead> <tbody> <tr> <td>000</td> <td>Unknown</td> </tr> <tr> <td>001</td> <td>1</td> </tr> <tr> <td>010</td> <td>2</td> </tr> <tr> <td>011</td> <td>3</td> </tr> <tr> <td>100</td> <td>4</td> </tr> <tr> <td>101</td> <td>- Reserved -</td> </tr> <tr> <td>110</td> <td>0</td> </tr> <tr> <td>111</td> <td>No class</td> </tr> </tbody> </table>	VALUE	STATE	000	Unknown	001	1	010	2	011	3	100	4	101	- Reserved -	110	0	111	No class
VALUE	STATE																			
000	Unknown																			
001	1																			
010	2																			
011	3																			
100	4																			
101	- Reserved -																			
110	0																			
111	No class																			
18 - 19	PoE Management	PoE control (read / write): <table border="1"> <thead> <tr> <th>VALUE</th> <th>STATE</th> </tr> </thead> <tbody> <tr> <td>00 (no write action)</td> <td>- Reserved -</td> </tr> <tr> <td>01</td> <td>PoE Off</td> </tr> <tr> <td>10</td> <td>PoE On</td> </tr> <tr> <td>11</td> <td>PoE Restart</td> </tr> </tbody> </table>	VALUE	STATE	00 (no write action)	- Reserved -	01	PoE Off	10	PoE On	11	PoE Restart								
VALUE	STATE																			
00 (no write action)	- Reserved -																			
01	PoE Off																			
10	PoE On																			
11	PoE Restart																			
16 - 17	PoE State	PoE status: <table border="1"> <thead> <tr> <th>VALUE</th> <th>STATE</th> </tr> </thead> <tbody> <tr> <td>00</td> <td>PoE halted</td> </tr> <tr> <td>01</td> <td>PoE on standby</td> </tr> <tr> <td>10</td> <td>PoE defective</td> </tr> <tr> <td>11</td> <td>PoE active</td> </tr> </tbody> </table>	VALUE	STATE	00	PoE halted	01	PoE on standby	10	PoE defective	11	PoE active								
VALUE	STATE																			
00	PoE halted																			
01	PoE on standby																			
10	PoE defective																			
11	PoE active																			
0 - 15	PoE Power	PoE output power expressed in tenths of a watt																		

B. HTTPS PROTOCOL

The HTTPS website provides product management and data processing-related information.

The chapter entitled “Embedded webserver” describes the use of the HTTPS website and the various data available. To log onto the embedded website, use the selected login and password. The chapter entitled “Configuration page - configuring the general settings” describes how to change the password.

C. SNMP PROTOCOL

2 MIBs are accessible over SNMP:

- ➔ The MIB-2, defined by the RFC1213 standard.
- ➔ The MIB SLAT-SDC is proprietary and specific to SLAT. It is common to the entire SYNAPS range. It can be downloaded from the embedded website (HTTPS) on the “Network” page.



IMPORTANT REMARK!

For the SNMP v1 and v2c, the Write Community is “private”.
For the SNMP v3, the user and the password must be configured.

MIB-2 variables

MIB-2		
VARIABLE	SNMP NAME	DESCRIPTION
Model	sysDesc	SYNAPS reference and version
Identifier	sysName	SYNAPS identifier (accessible in write mode, up to 16 characters)
Location	sysLocation	SYNAPS location (accessible in write mode, up to 32 characters)

MIB SLAT variables

MIB SLAT		
VARIABLE	SNMP NAME	DESCRIPTION
Model	model	SYNAPS reference and version.
Capacity	capacity	Battery capacity: energy expressed in watt-hours.
Serial number	serialNumber	SYNAPS serial number.
System state	systemState	32-bit variable giving the state of the SYNAPS system. Each time a change is made, this variable is sent in the form of an SNMP trap (for details of the variable, see “System state” table)*.
Gauge	energyGauge	Gauge in percentage corresponding to the amount of energy available in the battery. A value of 100 corresponds to a fully charged battery.
Output voltage	outputVoltage	Output voltage: the value is expressed in tenths of a volt.
Output current	outputCurrent	Output current: the value is expressed in tenths of an ampere.
Output power	outputPower	Instantaneous power supplied by the SYNAPS: the value is expressed in watts.
Mains power	mainsPower	Instantaneous mains power input: the value is expressed in watts.
Temperature	temperature	SYNAPS internal temperature: the value is expressed in °C.
Total discharged energy	totalDischargedEnergy	Amount of energy provided by the SYNAPS battery since initial commissioning: the value is expressed in tenths of a watt-hour.
Mains cut total number	mainsCutTotalNumber	Total number of power cuts since initial commissioning.
Output voltage adjustment	voutAdjust	Not applicable for SYNAPS PoE products.
Stealth mode threshold	stealthModeThreshold	Minimum battery charge level in percent for stealth mode. Accepted values: 25, 50, 75 or 100. The value 100 disables stealth mode.
Eco mode threshold	ecoModeThreshold	Minimum battery charge level in percent for eco mode. Accepted values: 50, 60, 70, 80 or 100. The value 100 disables eco mode.
Ethernet port X state:	ethernetPortX-State	32-bit variable giving the state of each Ethernet port, X representing the port number (for details of this variable, see Table “Details of Ethernet port X”).

* In order to use SNMP traps, the IP addresses of the SNMP servers to which the traps should be sent must be entered into the HTTPS website (see chapter entitled “Network page”).

D. BACNET IP PROTOCOL

The following objects are accessible in BACnet IP:

BACnet IP variables

PROPERTY	REMARK / VALUE	RW
Object_Identifier	Product instance, by default: 421000	RW-E
Object_Name	SYNAPS system name (max. 16 characters). By default: ""	RW-E
Object_Type	DEVICE (8)	R
System_Status	OPERATIONAL (0) or STATUS_NON_OPERATIONAL (4) if not ready	R
Vendor_Name	"SLAT"	R
Vendor_Identifier	954	R
Model_Name	Product type	R
Location	Product location (max. 32 characters). By default: ""	RW-E
Firmware_Revision	Communication firmware version	R
Application_Software_Version	""	R
Protocol_Version	1	R
Protocol_Revision	12	R
Protocol_Services_Supported	read-property, write-property, who-has, who-is, device-communication control	R
Protocol_Object_Types_Supported	DEVICE, ANALOG_VALUE, POSITIVE_INTEGER_VALUE	R
Object_List [17]	device, analog-value 0 ...10, positive_integer_value 0...4	R
Max_APDU_Length_Accepted	1476	R
Segmentation_Supported	NO_SEGMENTATION (3)	R
APDU_Timeout	3000	R
Number_Of_APDU_Retries	3	R
Device_Address_Binding	-	R
Database_Revision	0	R
Serial_Number	Serial number	R

R: Read Property, W: Write Property, -E: Saved in EEPROM

Analog value Object 0

ANALOG VALUE OBJECT 0		
PROPERTY	REMARK / VALUE	RW
Object_Identifier	analog-value 0	R
Object_Name	"Vout"	R
Object_Type	ANALOG_VALUE (2)	R
Description	"Output Voltage"	R
Present_Value	Output voltage	R
Status_Flags	IN_ALARM: 0 FAULT: 0 OVERRIDDEN: 0 OUT_OF_SERVICE: 0	R
Event_State	NORMAL (0)	R
Out_Of_Service	FALSE (0)	R
Units	Volts (5)	R

R: Read Property, W: Write Property, -E: Saved in EEPROM

Analog Value Object 1

ANALOG VALUE OBJECT 1		
PROPERTY	REMARK / VALUE	RW
Object_Identifier	analog-value 1	R
Object_Name	"Iout"	R
Object_Type	ANALOG_VALUE (2)	R
Description	"Output current"	R
Present_Value	Output current	R
Status_Flags	IN_ALARM: 0 FAULT: 0 OVERRIDDEN: 0 OUT_OF_SERVICE: 0	R
Event_State	NORMAL (0)	R
Out_Of_Service	FALSE (0)	R
Units	Amperes (3)	R

R: Read Property, W: Write Property, -E: Saved in EEPROM

Analog Value Object 2

ANALOG VALUE OBJECT 2		
PROPERTY	REMARK / VALUE	RW
Object_Identifier	analog-value 2	R
Object_Name	"Pout"	R
Object_Type	ANALOG_VALUE (2)	R
Description	"Output power"	R
Present_Value	Output power	R
Status_Flags	IN_ALARM: 0 FAULT: 0 OVERRIDDEN: 0 OUT_OF_SERVICE: 0	R
Event_State	NORMAL (0)	R
Out_Of_Service	FALSE (0)	R
Units	Watts (47)	R

R: Read Property, W: Write Property, -E: Saved in EEPROM

Analog Value Object 3

ANALOG VALUE OBJECT 3		
PROPERTY	REMARK / VALUE	RW
Object_Identifier	analog-value 3	R
Object_Name	"Pin"	R
Object_Type	ANALOG_VALUE (2)	R
Description	"Input power"	R
Present_Value	Mains power	R
Status_Flags	IN_ALARM: 0 FAULT: 0 OVERRIDDEN: 0 OUT_OF_SERVICE: 0	R
Event_State	NORMAL (0)	R
Out_Of_Service	FALSE (0)	R
Units	Watts (47)	R

R: Read Property, W: Write Property, -E: Saved in EEPROM

Analog Value Object 4

ANALOG VALUE OBJECT 4		
PROPERTY	REMARK / VALUE	RW
Object_Identifier	analog-value 4	R
Object_Name	"Temperature"	R
Object_Type	ANALOG_VALUE (2)	R
Description	"Internal temperature"	R
Present_Value	Internal temperature	R
Status_Flags	IN_ALARM: 0 FAULT: 0 OVERRIDDEN: 0 OUT_OF_SERVICE: 0	R
Event_State	NORMAL (0)	R
Out_Of_Service	FALSE (0)	R
Units	Degree Celsius (62)	R

R: Read Property, W: Write Property, -E: Saved in EEPROM

Analog Value Object 5

ANALOG VALUE OBJECT 5		
PROPERTY	REMARK / VALUE	RW
Object_Identifier	analog-value 5	R
Object_Name	"BatteryGauge"	R
Object_Type	ANALOG_VALUE (2)	R
Description	"Remaining autonomy"	R
Present_Value	Battery gauge	R
Status_Flags	IN_ALARM: 0 FAULT: 0 OVERRIDDEN: 0 OUT_OF_SERVICE: 0	R
Event_State	NORMAL (0)	R
Out_Of_Service	FALSE (0)	R
Units	Percent (98)	R

R: Read Property, W: Write Property, -E: Saved in EEPROM

Analog Value Object 6

ANALOG VALUE OBJECT 6		
PROPERTY	REMARK / VALUE	RW
Object_Identifier	analog-value 6	R
Object_Name	"Battery capacity"	R
Object_Type	ANALOG_VALUE (2)	R
Description	"Installed battery capacity"	R
Present_Value	Battery capacity	R
Status_Flags	IN_ALARM: 0 FAULT: 0 OVERRIDDEN: 0 OUT_OF_SERVICE: 0	R
Event_State	NORMAL (0)	R
Out_Of_Service	FALSE (0)	R
Units	Watt hours (18)	R

R: Read Property, W: Write Property, -E: Saved in EEPROM

Analog Value Object 7

ANALOG VALUE OBJECT 7		
PROPERTY	REMARK / VALUE	RW
Object_Identifier	analog-value 7	R
Object_Name	"StealthModeThreshold"	R
Object_Type	ANALOG_VALUE (2)	R
Description	"Minimum battery gauge level for Stealth Mode (25%, 50% or 75% - 100 disables Stealth Mode)"	R
Present_Value	Stealth Mode Threshold	R
Status_Flags	IN_ALARM: 0 FAULT: 0 OVERRIDDEN: 0 OUT_OF_SERVICE: 0	R
Event_State	NORMAL (0)	R
Out_Of_Service	FALSE (0)	R
Units	Percent (98)	R

R: Read Property, W: Write Property, -E: Saved in EEPROM

Analog Value Object 8

ANALOG VALUE OBJECT 8		
PROPERTY	REMARK / VALUE	RW
Object_Identifier	analog-value 8	R
Object_Name	"EcoModeThreshold"	R
Object_Type	ANALOG_VALUE (2)	R
Description	"Minimum battery gauge level for Eco Mode (50%, 60%, 70% or 80% - 100% disables Eco Mode)"	R
Present_Value	Eco Mode Threshold	R
Status_Flags	IN_ALARM: 0 FAULT: 0 OVERRIDDEN: 0 OUT_OF_SERVICE: 0	R
Event_State	NORMAL (0)	R
Out_Of_Service	FALSE (0)	R
Units	Percent (98)	R

R: Read Property, W: Write Property, -E: Saved in EEPROM

Analog Value Object 9

ANALOG VALUE OBJECT 9		
PROPERTY	REMARK / VALUE	RW
Object_Identifier	analog-value 9	R
Object_Name	"TotalDischargedEnergy"	R
Object_Type	ANALOG_VALUE (2)	R
Description	"Total discharged energy"	R
Present_Value	Total discharged energy	R
Status_Flags	IN_ALARM: 0 FAULT: 0 OVERRIDDEN: 0 OUT_OF_SERVICE: 0	R
Event_State	NORMAL (0)	R
Out_Of_Service	FALSE (0)	R
Units	Watt hours (18)	R

R: Read Property, W: Write Property, -E: Saved in EEPROM

Analog Value Object 10

ANALOG VALUE OBJECT 10		
PROPERTY	REMARK / VALUE	RW
Object_Identifier	analog-value 10	R
Object_Name	" MainsCut "	R
Object_Type	ANALOG_VALUE (2)	R
Description	"Mains cut total number"	R
Present_Value	Number of power cuts	RW
Status_Flags	IN_ALARM: 0 FAULT: 0 OVERRIDDEN: 0 OUT_OF_SERVICE: 0	R
Event_State	NORMAL (0)	R
Out_Of_Service	FALSE (0)	R
Units	No units (95)	R

R: Read Property, W: Write Property, -E: Saved in EEPROM

Positive Integer Value Object 0

POSITIVE INTEGER VALUE OBJECT 0		
PROPERTY	REMARK / VALUE	RW
Object_Identifier	positive-integer-value 0	R
Object_Name	"Default"	R
Object_Type	POSITIVE_INTEGER_VALUE (48)	R
Description	"System state register"	R
Present_Value	System state [32 bit]*	R
Status_Flags	IN_ALARM: 0 FAULT: 0 OVERRIDDEN: 0 OUT_OF_SERVICE: 0	R
Units	No units (95)	R

R: Read Property, W: Write Property, -E: Saved in EEPROM

* See details of the "System state" variable.

Positive Integer Value Object 1

POSITIVE INTEGER VALUE OBJECT 1		
PROPERTY	REMARK / VALUE	RW
Object_Identifier	positive-integer-value 1	R
Object_Name	"StealthMode"	R
Object_Type	POSITIVE_INTEGER_VALUE (48)	R
Description	"Stealth mode operating"	R
Present_Value	Stealth mode disabled if null, else enabled	RW
Status_Flags	IN_ALARM: 0 FAULT: 0 OVERRIDDEN: 0 OUT_OF_SERVICE: 0	R
Units	No units (95)	R

R: Read Property, W: Write Property, -E: Saved in EEPROM

Positive Integer Value Object 2

POSITIVE INTEGER VALUE OBJECT 2		
PROPERTY	REMARK / VALUE	RW
Object_Identifier	positive-integer-value 2	R
Object_Name	"SerialNumber"	R
Object_Type	POSITIVE_INTEGER_VALUE (48)	R
Description	"Serial number"	R
Present_Value	Serial number	R
Status_Flags	IN_ALARM: 0 FAULT: 0 OVERRIDDEN: 0 OUT_OF_SERVICE: 0	R
Units	No units (95)	R

R: Read Property, W: Write Property, -E: Saved in EEPROM

Positive Integer Value Object 3

POSITIVE INTEGER VALUE OBJECT 3		
PROPERTY	REMARK / VALUE	RW
Object_Identifier	positive-integer-value 3	R
Object_Name	"Ethernet1"	R
Object_Type	POSITIVE_INTEGER_VALUE (48)	R
Description	"1st Ethernet port state"	R
Present_Value	Port 1* state	R
Status_Flags	IN_ALARM: 0 FAULT: 0 OVERRIDDEN: 0 OUT_OF_SERVICE: 0	R
Units	No units (95)	R

R: Read Property, W: Write Property, -E: Saved in EEPROM

* For details of the variable, see the "Ethernet port X state" table.

**The table above is the object for Ethernet port 1. For port 2 use the same table with the following formulas:
(X = port number):**

- ➔ Object_Identifier ➔ positive-integer-value 2 + X
- ➔ Object Name ➔ "EthernetX"
- ➔ Description: ➔ "Xth Ethernet port state"
- ➔ Present value: ➔ Port X state

See details of the "Present value - Port X state".

13 TECHNICAL DATA

13-1 MAINS INPUT ELECTRICAL CHARACTERISTICS

Mains input electrical characteristics

MAINS INPUT	
AC network voltage	220-240 V AC (198-264 V AC)
Frequency	50-60 Hz (45-65 Hz)
Class	1
Inrush current	Limited by NTC
Neutral regime	TT, TN, IT
Primary short-circuit protection	Slow-blow fuse on the phase
Characteristics of the built-in fuse	3,15 A (slow-blow, internal)
Shock wave protection	Differential mode by varistor and filter
Primary current	@ 230 VAC : 2,1 A A
	@ 195,5 VAC : 1,7 A A
	@ 264,5 VAC : 1,85 A A
Residual consumption in eco and stealth mode	< 1 W
Circuit breaker to be provided upstream	Curve D (recommended rating 4 A)

CURRENT BEHAVIOUR:

➔ Inrush current at start-up

Figure 12-1 - Oscillogram - inrush current



Table 12-2 - Description of the oscillogram - inrush current

TEST CONDITIONS	
Input voltage	240 V AC
Output voltage and current	55 V DC; no load
Ambient temperature	+20°C
DESCRIPTION OF THE DIAGRAM	
Input voltage	10 A / DIV
Time scale	4 ms / DIV

13-2 POE ELECTRICAL CHARACTERISTICS

Mains input electrical characteristics

OUTPUT	
Standards	IEEE 802.3af, IEEE 802.3at
Rated voltage U_n	55 V DC
Voltage precision	< 5%
PoE budget	15 à 90 W/Port, budget total PoE 180 W*
Courant limitation	de I_n à $I_n+15\%$ pour tension de sortie > 50% de U_n
HF ripple peak-peak (20 MHz-50 Ω)	< 4% de U_n
Switching frequency	65 kHz+/-10%
Effective LF ripple	< 0.2% de U_n
Static and dynamic regulation characteristics	< 5% de U_n pour des variations cumulées du secteur et de la charge (de 10 à 90%)
Protection	fusible
η (Smart backup) @ 25% of use load	74%
η (Smart backup) @ 75% of use load	83%
η (Smart backup) @ 100% of use load	88%
Protection contre les courts-circuits en sortie	par coupure de l'alimentation avec redémarrage cyclique
Protection contre les surtensions en sortie utilisateur	dérégulation ou erreur de branchement, par coupure avec redémarrage cyclique si tension de sortie > $U_n+10\%$
Court-circuit si	$U_{sortie} < 30 V$ ou $I > 1,2 A$

* The permitted available output power with the SYNAPS POE5F V 8P2F C is 180 W W

13-3 FUNCTIONAL CHARACTERISTICS

One user output permanently supplies a constant voltage (55 V DC) to the equipment which has to be powered. In the event of a power outage, the built-in backup maintains the electrical power supply to the equipment connected to the UPS for the duration defined when your SYNAPS POE5F V 8P2F C was chosen.

An Ethernet connection is used to remotely retrieve information including the analogue values (user voltages and currents, backup, autonomy, internal electronic temperature).

The DHCP is active by default. The HTTPS webserver makes it possible to configure the communication parameters amongst other things, and to choose the operating mode.

One Ethernet status LED (Link) and one PoE LED per PoE port, plus two Ethernet status LEDs (Uplink) for the uplink port are also available.

The stealth function makes it possible to shed load from the network while guaranteeing backup autonomy.

13-4 ENVIRONMENTAL SPECIFICATIONS

Environmental specifications

ENVIRONMENTAL SPECIFICATIONS		
Storage temperature		-25 ... +60°C
Operating temperature		-10°C ... 45°C*
Relative humidity	in operation	0 ... 100% condensing
Altitude	Above 2000 m, the temperature is lowered by 5% every 1000 m.	

* Up to 50°C for a maximum power of 90W.

13-5 SAFETY STANDARDS

The product is designed to meet the LV and EMC directives (immunity and emission).

SECTION	STANDARD NUMBER	TITLE/ CONTENT
LVD Safety	EN 62368-1 (2020)	Audio/video, information and communication technology equipment Part 1: Safety requirements
LVD Safety	EN 62368-3 (2020)	Audio/video, information and communication technology equipment Part 3: Safety aspects relating to the transfer of d.c. power by means of communication cables and accesses

13-6 EMC STANDARDS

SECTION	STANDARD NUMBER	TITLE/ CONTENT
Immunity	EN 61000-6-1 (2007)	Immunity standard for residential, commercial and light-industrial environments (generic standard)
Immunity	EN 61000-6-2 (2005)	Immunity standard for industrial environments (generic standard)
Emission	EN 61000-6-3 (2007)	Emission standard for residential, commercial and light industrial environments (generic standard).
Emission	EN 61000-6-4 (2007) + A1 (2011)	Emission standard for industrial environments (generic standard).
Emission	EN 61000-3-2 (2014) (class A)	Limits for harmonic current emissions (equipment input current <= 16 A per phase).
Emission	EN 55032 (2015) (class B)	Electromagnetic compatibility of multimedia equipment.

13-7 IEEE STANDARDS

The standards for local and metropolitan area networks are:

N° norme	Contenu
IEEE 802.1D	Standard Spanning Tree / Multicast
IEEE 802.1w	Rapid Spanning Tree (RSTP)
IEEE 802.1Q	VLAN
IEEE 802.1X	Radius
IEEE 802.3ad	Link Aggregation Control Protocol (LACP)
IEEE 802.3i	10BaseT
IEEE 802.3u	100BaseT(X) and 100BaseFX
IEEE 802.3ab	1000BaseT(X)
IEEE 802.3z	1000BaseX
IEEE 802.3x	Flow Control
IEEE 802.3af	PoE
IEEE 802.3at	PoE+
IEEE 802.3bt	HiPoE
IEEE 802.3az	Energy Efficient Ethernet

14 MAINTENANCE AND TROUBLESHOOTING

14-1 MAINTENANCE

The product has been designed to function for a long period of time **without requiring maintenance**.



IMPORTANT REMARK!

All operations on the product must be performed by qualified personnel only. For additional technical assistance, contact the SLAT hotline: +33 4 78 66 63 70 For an RMA request (authorization to return goods), refer to chapter 15-2.



DANGER!

At no time should the cover of the charger power supply be opened, even for maintenance purposes.

14-2 TROUBLESHOOTING

Unexpected situations may arise during installation, commissioning or use. The table below may be consulted in case of problems. It contains a list of possible problems with their corresponding causes and solutions.

Problems, causes and solutions

PROBLEM	COMMUNICATION FAULT	CAUSE	SOLUTION
The product does not start. The <i>Status and PoE LED</i> remains off.	No communication	The mains voltage is not connected or is not present.	Check if the mains voltage is connected properly.
		The mains voltage fuse is faulty or absent.	Replace the product.
The <i>Status LED</i> is red. The output voltage is OK.	Backup fault	Backup malfunction; the backup is disconnected or has failed.	Replace the product.
	Fan rotor failure	Fan rotor locked	Replace the product.
	Temperature sensor failure	Temperature sensor failure out of order or disconnected	Replace the product.
	Communication Failure	With power supply out of order	Replace the product.
		With the switch out of order	Replace the product.
Charger fault	Charger malfunction.	The charger has failed. Replace the product.	
The <i>Status LED</i> is red + slow flashing The <i>PoE LED</i> is red	Internal communication fault	Wiring problem controller/power supply	Replace the product.
	Output overload	There is a slight overload on the output.	Lower the output load until the current is less than the maximum output value.
No connection: The <i>Link LED</i> of the Port 1 to 22 are not illuminated.	No communication	Bad Ethernet connection.	Verify the connection and use an appropriate Ethernet cable.
The <i>Status LED</i> and one <i>Link/Act LED</i> are illuminated but there is no communication.	No communication	Configuration problem.	Check that the configuration of the SDC and the computer are compatible.
One LED <i>PoE (RJ45)</i> is green+ fast flashing	Short-circuit	Short-circuit to the corresponding <i>PoE</i> port	Delete the short-circuit
The product's IP address is lost.	No communication	-	Perform a factory configuration reset.
The administrator's password has been lost.	No communication	-	Perform a factory configuration reset.

15 WARRANTY AND PRODUCT RETURNS

15-1 WARRANTY

The equipment is guaranteed for two years from the date of delivery (ex-works). It is strictly limited to reimbursement or replacement (at our discretion and without compensation of any sort) of parts recognised as faulty by our services, following the return of the product to our workshops at the buyer's expense. The replacement or repair of equipment is possible only in our workshops. In order to allow our customers to benefit from the latest technical improvements, SLAT reserves the right to carry out any alterations considered appropriate.



IMPORTANT REMARK!

Mechanical opening of the covers of the sub-assemblies inside the product cancels **the manufacturer warranty!**

15-2 PRODUCT RETURNS

PRODUCT UNDER WARRANTY

For the maintenance of your products under warranty, SLAT offer the best solution to facilitate your repairs and minimise lead times:

- ➔ Contact the Customer Service department using the form available on our web site www.slat.com, taking care to fill in all the required fields.
- ➔ The RMA form will be processed and sent back by the SLAT account manager.
- ➔ After receiving your RMA form, return two copies with your product(s), one **INSIDE** the package and the other on the **OUTSIDE** of the package for warehouse identification purposes, thereby guaranteeing traceability of your product.
- ➔ The repaired or replaced product(s) will be returned within a maximum of 15 business days.

15-3 PRODUCT NOT UNDER WARRANTY

PRODUCT REPAIR BY SLAT

Contact Customer Services at service.client@slat.fr making sure that you provide all the following information:

- ➔ Last name / First name
- ➔ Company / Full address / Telephone / Email
- ➔ Exact model of the product (indicated on the product label) / SLAT reference (indicated on the product label, code number) / Serial No. / Quantity / Problems(s) encountered (describe the faults encountered with the product)

THE FORM TO REQUEST THE RMA NUMBER IS ALSO AVAILABLE AT WWW.SLAT.COM.

The account manager will send the RMA form by email together with a quote according to the relevant product range.

After receiving your RMA form, return two copies with your product(s), one **INSIDE** the package and the other on the **OUTSIDE** of the package for warehouse identification purposes, thereby guaranteeing traceability of your product. The repairs will be performed only after the receipt of the accepted quote together with a repair order form. If the quote is rejected, please return it to service.client@slat.fr marked "refused" and specify whether the equipment should be destroyed or returned in its existing condition (in this case a charge of €150 will be invoiced for handling costs).

The repaired or replaced product(s) will be returned within a maximum of 15 business days. A new three-month warranty is attributed to the product in question.

**CONDITIONS: AUTHORISATION TO RETURN PRODUCTS IS ISSUED BY SLAT.
AN RMA NUMBER IS ASSIGNED TO EACH PRODUCT TO BE RETURNED. EACH RMA NUMBER IS VALID FOR 30 DAYS. NO EQUIPMENT MAY BE RETURNED WITHOUT PRIOR ISSUANCE OF AN RMA NUMBER.**

For additional technical assistance, contact the SLAT hotline: +33 4 78 66 63 70



SLAT

SLAT SAS

11 rue Jean Elysée Dupuy - BP66
69543 Champagne au Mont d'or - France
+33 4 78 66 63 70
comm@slat.fr
www.slat.com

SLAT GmbH

Leitzstraße 45
70469 Stuttgart – Deutschland
+49 711 899 890 92
info@slat-gmbh.de
www.slat.com